

## 30V N-Channel MOSFETs

### General Description

These N-Channel enhancement mode power field effect transistors are using trench DMOS technology. This advanced technology has been especially tailored to minimize on-state resistance, provide superior switching performance, and withstand high energy pulse in the avalanche and commutation mode. These devices are well suited for high efficiency fast switching applications.

BVDSS	RDSON	ID
30V	2.6mΩ	90A

### Features

- 30V, 90A, RDS(ON) = 2.6mΩ@VGS = 10V
- *Improved dv/dt capability*
- *Fast switching*
- *100% EAS Guaranteed*
- *Green Device Available*

### TO-252 Pin Configuration

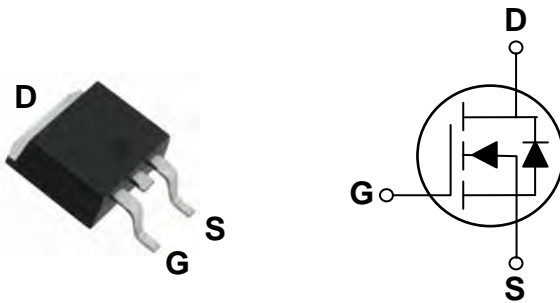

### Applications

- *MB / VGA / Vcore*
- *POL Applications*
- *SMPS 2<sup>nd</sup> SR*

### Absolute Maximum Ratings (Tc=25°C unless otherwise noted)

Symbol	Parameter	Rating	Units
V <sub>DS</sub>	Drain-Source Voltage	30	V
V <sub>GS</sub>	Gate-Source Voltage	± 20	V
I <sub>D</sub>	Drain Current – Continuous (T <sub>C</sub> =25°C)	90	A
	Drain Current – Continuous (T <sub>C</sub> =100°C)	57	A
I <sub>DM</sub>	Drain Current – Pulsed <sup>1</sup>	360	A
EAS	Single Pulse Avalanche Energy <sup>2</sup>	180	mJ
IAS	Single Pulse Avalanche Current <sup>2</sup>	60	A
P <sub>D</sub>	Power Dissipation (T <sub>C</sub> =25°C)	100	W
	Power Dissipation – Derate above 25°C	0.8	W/°C
T <sub>STG</sub>	Storage Temperature Range	-55 to 150	°C
T <sub>J</sub>	Operating Junction Temperature Range	-55 to 150	°C

### Thermal Characteristics

Symbol	Parameter	Typ.	Max.	Unit
R <sub>θJA</sub>	Thermal Resistance Junction to ambient	---	62	°C/W
R <sub>θJC</sub>	Thermal Resistance Junction to Case	---	1.25	°C/W



# FTK3960D

## 30V N-Channel MOSFETs

Electrical Characteristics ( $T_J=25\text{ }^\circ\text{C}$ , unless otherwise noted)

### Off Characteristics

Symbol	Parameter	Conditions	Min.	Typ.	Max.	Unit
$BV_{DSS}$	Drain-Source Breakdown Voltage	$V_{GS}=0V, I_D=250\mu A$	30	---	---	V
$\Delta BV_{DSS}/\Delta T_J$	$BV_{DSS}$ Temperature Coefficient	Reference to $25\text{ }^\circ\text{C}$ , $I_D=1mA$	---	0.03	---	V/ $^\circ\text{C}$
$I_{DSS}$	Drain-Source Leakage Current	$V_{DS}=30V, V_{GS}=0V, T_J=25\text{ }^\circ\text{C}$	---	---	1	$\mu A$
		$V_{DS}=24V, V_{GS}=0V, T_J=125\text{ }^\circ\text{C}$	---	---	10	$\mu A$
$I_{GSS}$	Gate-Source Leakage Current	$V_{GS}=\pm 20V, V_{DS}=0V$	---	---	$\pm 100$	nA

### On Characteristics

$R_{DS(ON)}$	Static Drain-Source On-Resistance <sup>3</sup>	$V_{GS}=10V, I_D=30A$	---	1.9	2.6	m $\Omega$
		$V_{GS}=4.5V, I_D=15A$	---	2.5	3.4	m $\Omega$
$V_{GS(th)}$	Gate Threshold Voltage	$V_{GS}=V_{DS}, I_D=250\mu A$	1.2	1.6	2.5	V
$\Delta V_{GS(th)}$	$V_{GS(th)}$ Temperature Coefficient		---	-5	---	mV/ $^\circ\text{C}$
gfs	Forward Transconductance	$V_{DS}=10V, I_D=2A$	---	16	---	S

### Dynamic Characteristics

$Q_g$	Total Gate Charge <sup>3, 4</sup>	$V_{DS}=15V, V_{GS}=4.5V, I_D=24A$	---	40	75	nC
$Q_{gs}$	Gate-Source Charge <sup>3, 4</sup>		---	6	12	
$Q_{gd}$	Gate-Drain Charge <sup>3, 4</sup>		---	19	35	
$T_{d(on)}$	Turn-On Delay Time <sup>3, 4</sup>	$V_{DD}=15V, V_{GS}=10V, R_G=1\Omega$ $I_D=1A$	---	20	40	ns
$T_r$	Rise Time <sup>3, 4</sup>		---	32	60	
$T_{d(off)}$	Turn-Off Delay Time <sup>3, 4</sup>		---	75	130	
$T_f$	Fall Time <sup>3, 4</sup>		---	28	55	
$C_{iss}$	Input Capacitance	$V_{DS}=25V, V_{GS}=0V, F=1MHz$	---	4800	8000	pF
$C_{oss}$	Output Capacitance		---	735	1300	
$C_{rss}$	Reverse Transfer Capacitance		---	420	800	
$R_g$	Gate resistance		$V_{GS}=0V, V_{DS}=0V, F=1MHz$	---	1.6	

### Drain-Source Diode Characteristics

Symbol	Parameter	Conditions	Min.	Typ.	Max.	Unit
$I_S$	Continuous Source Current	$V_G=V_D=0V$ , Force Current	---	---	90	A
$I_{SM}$	Pulsed Source Current <sup>3</sup>		---	---	180	A
$V_{SD}$	Diode Forward Voltage <sup>3</sup>	$V_{GS}=0V, I_S=1A, T_J=25\text{ }^\circ\text{C}$	---	---	1	V
$t_{rr}$	Reverse Recovery Time	$V_{DS}=30V, I_S=1A, di/dt=100A/\mu s$	---	49	85	ns
$Q_{rr}$	Reverse Recovery Charge	$T_J=25\text{ }^\circ\text{C}$	---	18	35	nC

Note :

1. Repetitive Rating : Pulsed width limited by maximum junction temperature.
2.  $V_{DD}=25V, V_{GS}=10V, L=0.1mH, I_{AS}=60A, R_G=25\Omega$ , Starting  $T_J=25\text{ }^\circ\text{C}$ .
3. The data tested by pulsed, pulse width  $\leq 300\mu s$ , duty cycle  $\leq 2\%$ .
4. Essentially independent of operating temperature.

## Typical Performance Characteristics

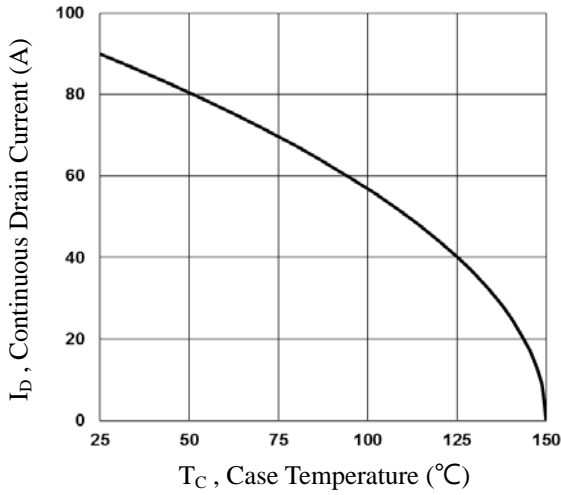

Fig.1 Continuous Drain Current vs.  $T_C$

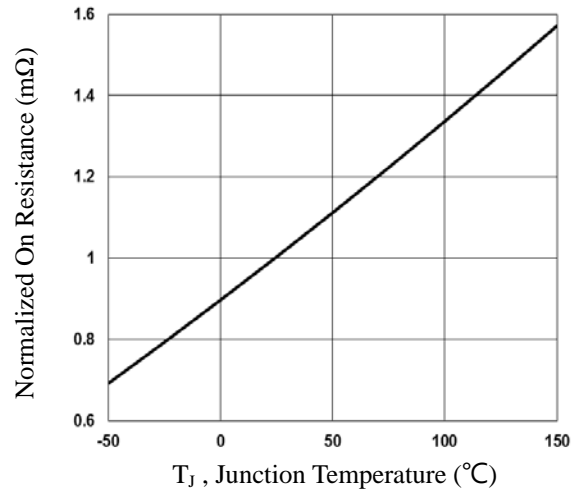

Fig.2 Normalized  $R_{DS(on)}$  vs.  $T_J$

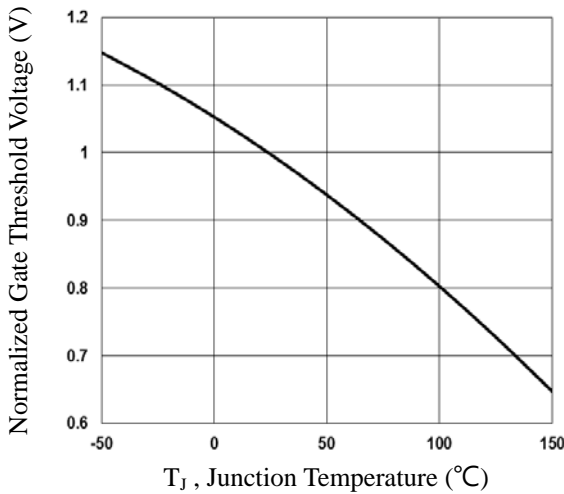

Fig.3 Normalized  $V_{th}$  vs.  $T_J$

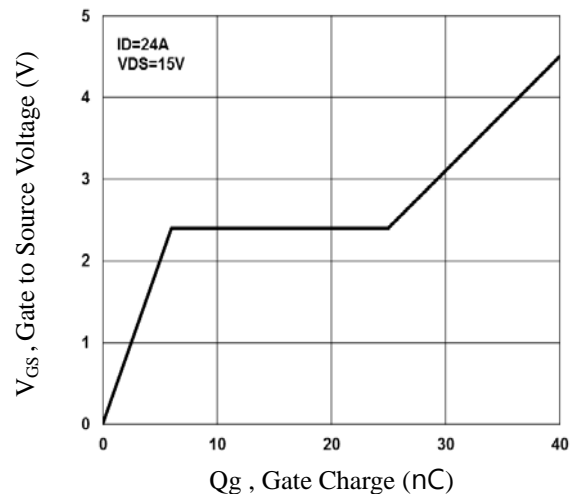

Fig.4 Gate Charge Waveform

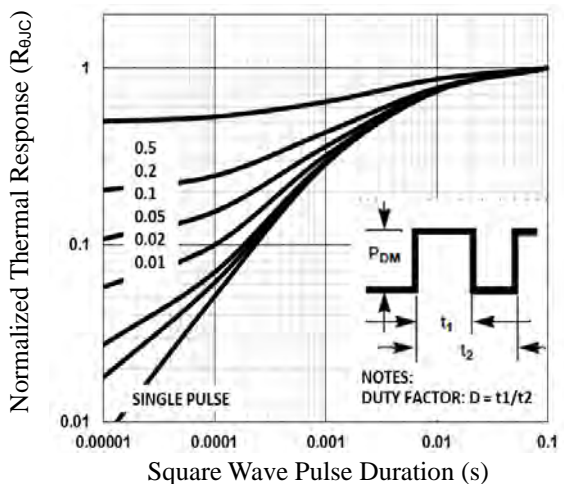

Fig.5 Normalized Transient Impedance

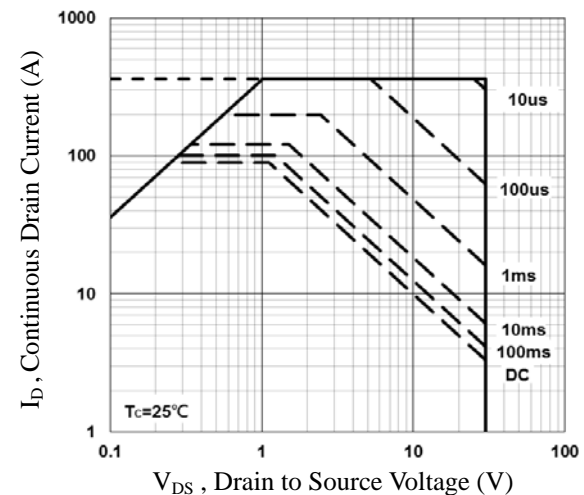

Fig.6 Maximum Safe Operation Area

## Typical Performance Characteristics(Con.)

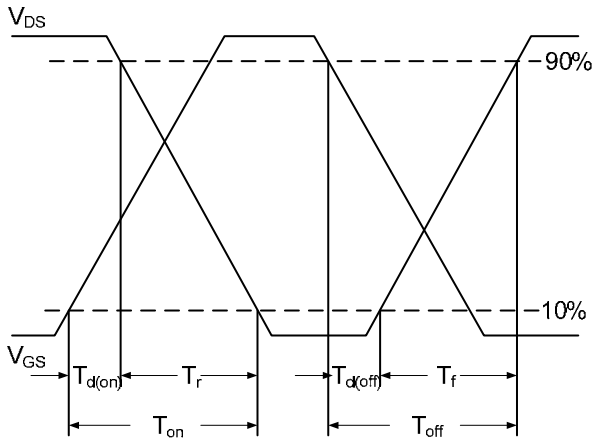

Fig.7 Switching Time Waveform

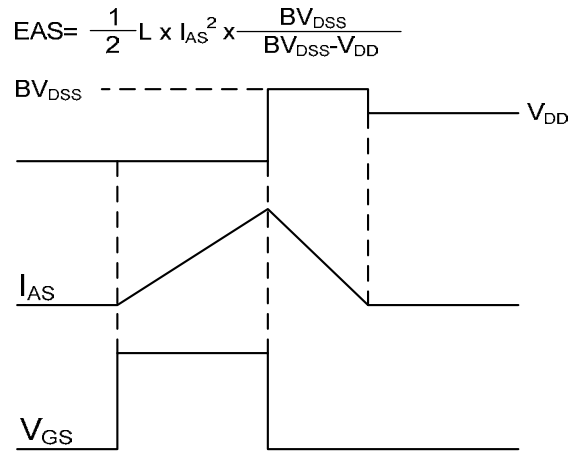
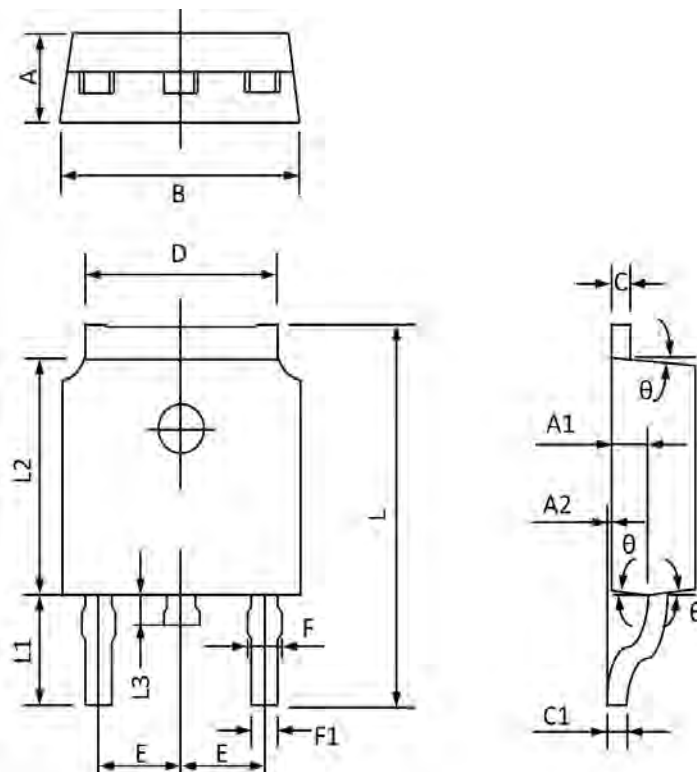

Fig.8 EAS Waveform

## TO-252 PACKAGE INFORMATION



Symbol	Dimensions In Millimeters		Dimensions In Inches	
	MAX	MIN	MAX	MIN
A	2.400	2.200	0.094	0.087
A1	1.110	0.910	0.044	0.036
A2	0.150	0.000	0.006	0.000
B	6.800	6.400	0.268	0.252
C	0.580	0.450	0.023	0.018
C1	0.580	0.460	0.023	0.018
D	5.500	5.100	0.217	0.201
E	2.386	2.186	0.094	0.086
F	0.940	0.600	0.037	0.024
F1	0.860	0.500	0.034	0.020
L	10.400	9.400	0.409	0.370
L1	3.000	2.400	0.118	0.094
L2	6.200	5.400	0.244	0.213
L3	1.200	0.600	0.047	0.024
θ	9°	3°	9°	3°