

60V P-Channel MOSFETs

General Description

These P-Channel enhancement mode power field effect transistors are using trench DMOS technology. This advanced technology has been especially tailored to minimize on-state resistance, provide superior switching performance, and withstand high energy pulse in the avalanche and commutation mode. These devices are well suited for high efficiency fast switching applications.

| | | |
|-------|-------|-----|
| BVDSS | RDSON | ID |
| -60V | 180mΩ | -7A |

Features

- -60V,-7A, $R_{DS(ON)} = 180m\Omega @ V_{GS} = -10V$
- Improved dv/dt capability
- Fast switching
- 100% EAS Guaranteed
- Green Device Available

TO252 Pin Configuration

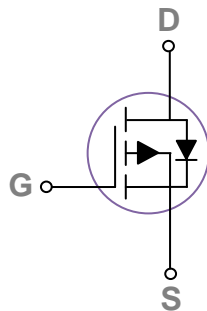
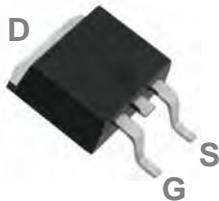

Applications

- Motor Drive
- Power Tools
- LED Lighting

Absolute Maximum Ratings $T_c=25^\circ\text{C}$ unless otherwise noted

| Symbol | Parameter | Rating | Units |
|-----------|--|------------|---------------------|
| V_{DS} | Drain-Source Voltage | -60 | V |
| V_{GS} | Gate-Source Voltage | ± 20 | V |
| I_D | Drain Current – Continuous ($T_c=25^\circ\text{C}$) | -7 | A |
| | Drain Current – Continuous ($T_c=100^\circ\text{C}$) | -4.4 | A |
| I_{DM} | Drain Current – Pulsed ¹ | -28 | A |
| EAS | Single Pulse Avalanche Energy ² | 32 | mJ |
| IAS | Single Pulse Avalanche Current ² | -8 | A |
| P_D | Power Dissipation ($T_c=25^\circ\text{C}$) | 15.6 | W |
| | Power Dissipation – Derate above 25°C | 0.125 | W/ $^\circ\text{C}$ |
| T_{STG} | Storage Temperature Range | -50 to 150 | $^\circ\text{C}$ |
| T_J | Operating Junction Temperature Range | -50 to 150 | $^\circ\text{C}$ |

Thermal Characteristics

| Symbol | Parameter | Typ. | Max. | Unit |
|-----------------|--|------|------|---------------------------|
| $R_{\theta JA}$ | Thermal Resistance Junction to ambient | --- | 62 | $^\circ\text{C}/\text{W}$ |
| $R_{\theta JC}$ | Thermal Resistance Junction to Case | --- | 8 | $^\circ\text{C}/\text{W}$ |



FTK6911D

60V P-Channel MOSFETs

Electrical Characteristics ($T_J=25\text{ }^\circ\text{C}$, unless otherwise noted)

Off Characteristics

| Symbol | Parameter | Conditions | Min. | Typ. | Max. | Unit |
|------------------------------|------------------------------------|---|------|-------|-----------|---------------------|
| BV_{DSS} | Drain-Source Breakdown Voltage | $V_{GS}=0V, I_D=-250\mu A$ | -60 | --- | --- | V |
| $\Delta BV_{DSS}/\Delta T_J$ | BV_{DSS} Temperature Coefficient | Reference to $25\text{ }^\circ\text{C}$, $I_D=-1mA$ | --- | -0.05 | --- | V/ $^\circ\text{C}$ |
| I_{DSS} | Drain-Source Leakage Current | $V_{DS}=-60V, V_{GS}=0V, T_J=25\text{ }^\circ\text{C}$ | --- | --- | -1 | μA |
| | | $V_{DS}=-48V, V_{GS}=0V, T_J=125\text{ }^\circ\text{C}$ | --- | --- | -10 | μA |
| I_{GSS} | Gate-Source Leakage Current | $V_{GS}=\pm 20V, V_{DS}=0V$ | --- | --- | ± 100 | nA |

On Characteristics

| | | | | | | |
|---------------------|--------------------------------------|--------------------------------|------|------|------|----------------------|
| $R_{DS(ON)}$ | Static Drain-Source On-Resistance | $V_{GS}=-10V, I_D=-3A$ | --- | 153 | 180 | m Ω |
| | | $V_{GS}=-4.5V, I_D=-1.5A$ | --- | 198 | 220 | m Ω |
| $V_{GS(th)}$ | Gate Threshold Voltage | $V_{GS}=V_{DS}, I_D=-250\mu A$ | -1.2 | -1.6 | -2.5 | V |
| $\Delta V_{GS(th)}$ | $V_{GS(th)}$ Temperature Coefficient | | --- | 5 | --- | mV/ $^\circ\text{C}$ |
| g_{fs} | Forward Transconductance | $V_{DS}=-10V, I_D=-2A$ | --- | 3 | --- | S |

Dynamic and switching Characteristics

| | | | | | | |
|--------------|------------------------------------|--|-----|------|-----|----|
| Q_g | Total Gate Charge ^{3,4} | $V_{DS}=-30V, V_{GS}=-10V, I_D=-3A$ | --- | 8.2 | 12 | nC |
| Q_{gs} | Gate-Source Charge ^{3,4} | | --- | 1.8 | 3.6 | |
| Q_{gd} | Gate-Drain Charge ^{3,4} | | --- | 1.5 | 3 | |
| $T_{d(on)}$ | Turn-On Delay Time ^{3,4} | $V_{DD}=-30V, V_{GS}=-10V, R_G=6\Omega$ $I_D=-1A$ | --- | 5.2 | 10 | ns |
| T_r | Rise Time ^{3,4} | | --- | 19 | 36 | |
| $T_{d(off)}$ | Turn-Off Delay Time ^{3,4} | | --- | 35 | 67 | |
| T_f | Fall Time ^{3,4} | | --- | 10.6 | 20 | |
| C_{iss} | Input Capacitance | $V_{DS}=-30V, V_{GS}=0V, F=1MHz$ | --- | 425 | 615 | pF |
| C_{oss} | Output Capacitance | | --- | 35 | 50 | |
| C_{rss} | Reverse Transfer Capacitance | | --- | 20 | 30 | |

Drain-Source Diode Characteristics and Maximum Ratings

| Symbol | Parameter | Conditions | Min. | Typ. | Max. | Unit |
|----------|---------------------------|--|------|------|------|------|
| I_S | Continuous Source Current | $V_G=V_D=0V$, Force Current | --- | --- | -7 | A |
| I_{SM} | Pulsed Source Current | | --- | --- | -28 | A |
| V_{SD} | Diode Forward Voltage | $V_{GS}=0V, I_S=-1A, T_J=25\text{ }^\circ\text{C}$ | --- | --- | -1 | V |

Note :

1. Repetitive Rating : Pulsed width limited by maximum junction temperature.
2. $V_{DD}=-25V, V_{GS}=-10V, L=1mH, I_{AS}=-8A, R_G=25\Omega$, Starting $T_J=25\text{ }^\circ\text{C}$.
3. The data tested by pulsed, pulse width $\leq 300\mu s$, duty cycle $\leq 2\%$.
4. Essentially independent of operating temperature.

60V P-Channel MOSFETs

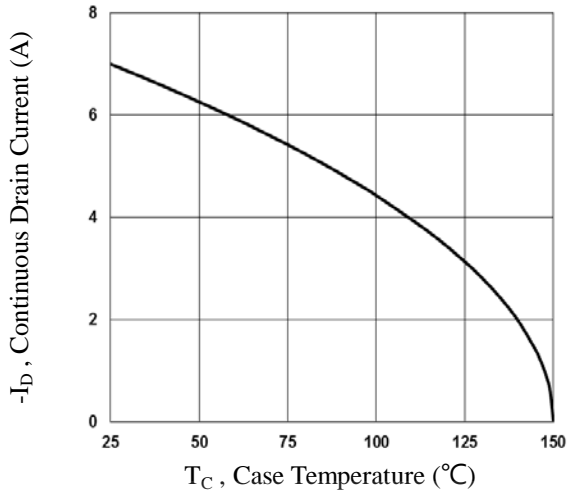

Fig.1 Continuous Drain Current vs. T_c

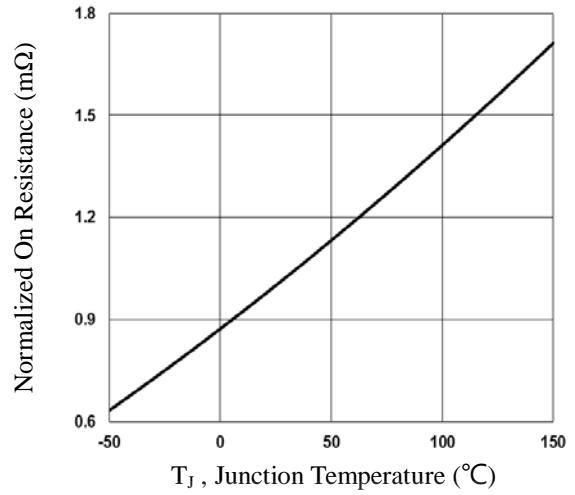

Fig.2 Normalized $R_{DS(on)}$ vs. T_j

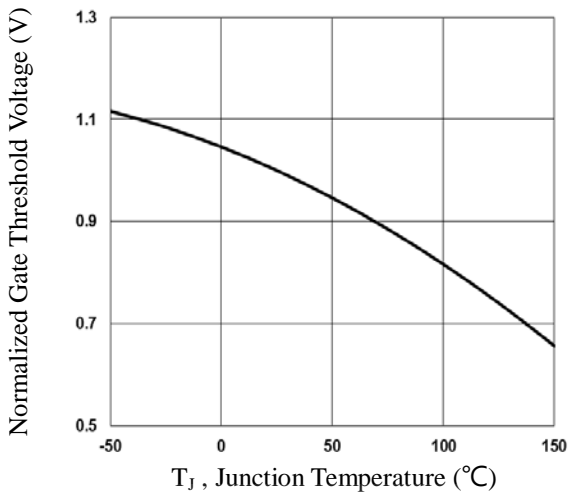

Fig.3 Normalized V_{th} vs. T_j

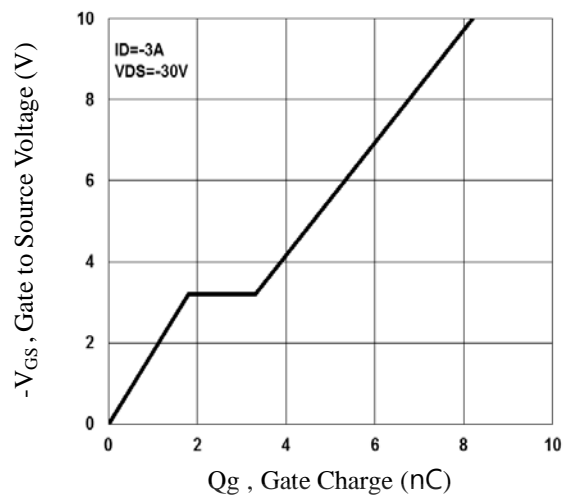

Fig.4 Gate Charge Waveform

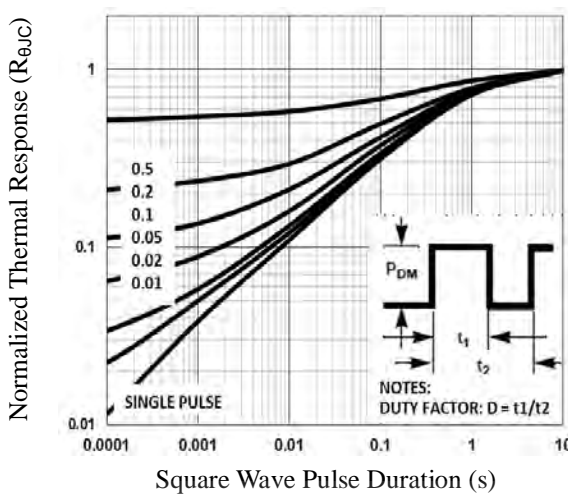

Fig.5 Normalized Transient Impedance

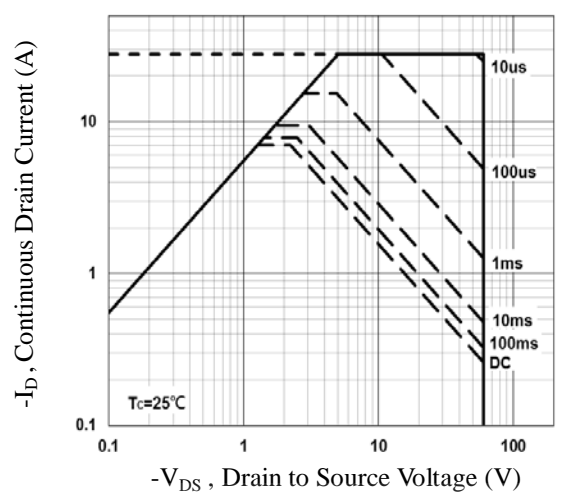

Fig.6 Maximum Safe Operation Area

60V P-Channel MOSFETs

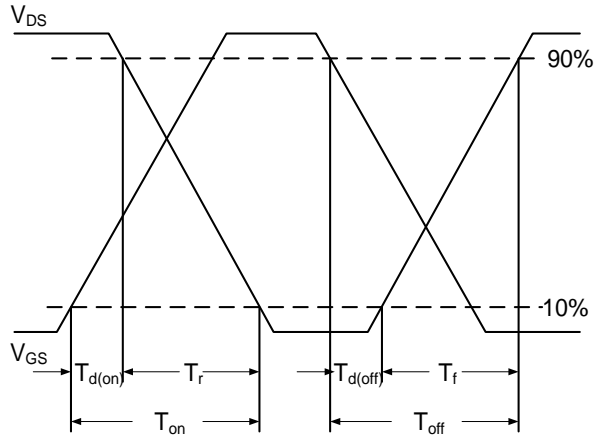

Fig.7 Switching Time Waveform

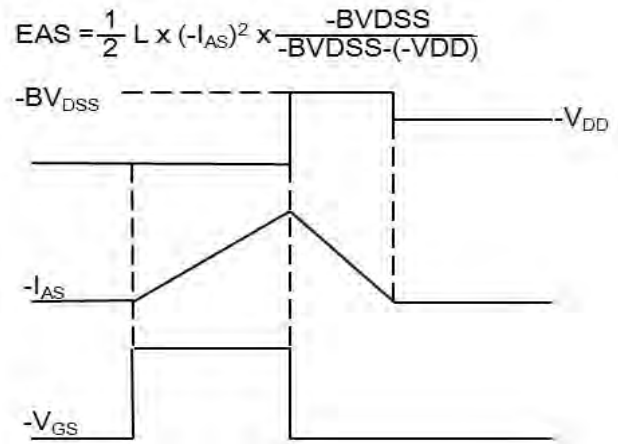
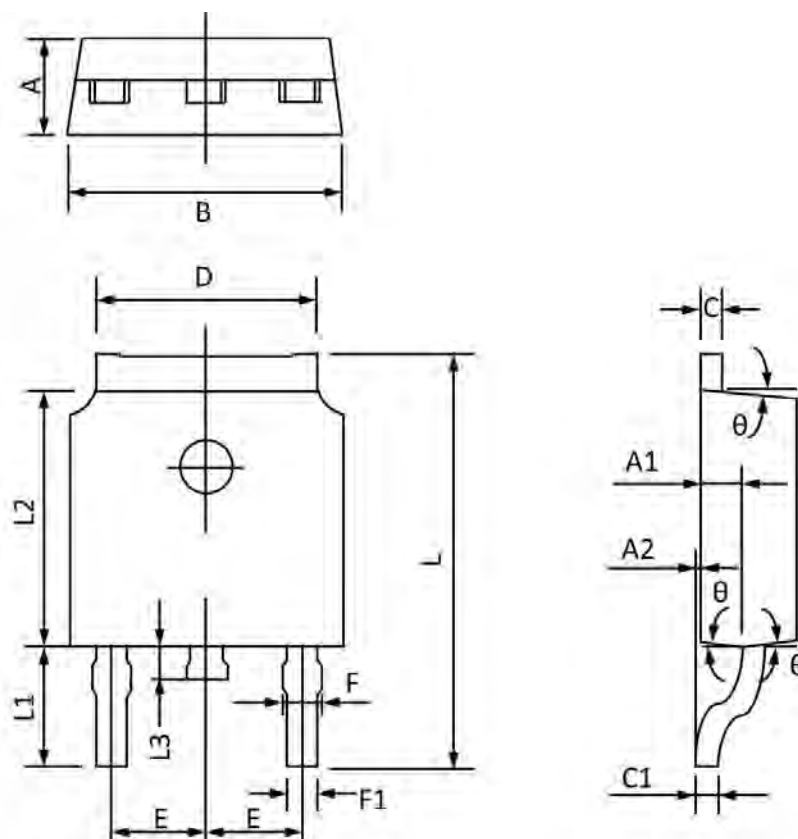

Fig.8 EAS Waveform

60V P-Channel MOSFETs

TO252 PACKAGE INFORMATION



| Symbol | Dimensions In Millimeters | | Dimensions In Inches | |
|--------|---------------------------|-------|----------------------|-------|
| | Min | Max | Min | Max |
| A | 2.20 | 2.40 | 0.087 | 0.094 |
| A1 | 0.91 | 1.11 | 0.036 | 0.044 |
| A2 | 0.00 | 0.15 | 0.000 | 0.006 |
| B | 6.50 | 6.70 | 0.256 | 0.264 |
| C | 0.46 | 0.580 | 0.018 | 0.230 |
| C1 | 0.46 | 0.580 | 0.018 | 0.030 |
| D | 5.10 | 5.46 | 0.201 | 0.215 |
| E | 2.186 | 2.386 | 0.086 | 0.094 |
| F | 0.74 | 0.94 | 0.029 | 0.037 |
| F1 | 0.660 | 0.860 | 0.026 | 0.034 |
| L | 9.80 | 10.40 | 0.386 | 0.409 |
| L1 | 2.9REF | | 0.114REF | |
| L2 | 6.00 | 6.20 | 0.236 | 0.244 |
| L3 | 0.60 | 1.00 | 0.024 | 0.039 |
| θ | 3° | 9° | 3° | 9° |