

## SOT-89-3L Plastic-Encapsulate MOSFETS

### FTK03N10

$V_{(BR)DSS}$	$R_{DS(on)MAX}$	$I_D$
100V	140mΩ @ 10V	3A
	190mΩ @ 4.5V	

**SOT-89-3L**

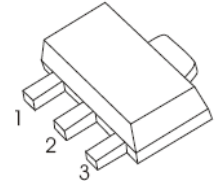

1. GATE
2. DRAIN
3. SOURCE

#### DESCRIPTION

The FTK03N10 uses advanced trench technology and design to provide excellent  $R_{DS(ON)}$  with low gate charge. This device is suitable for use in a wide variety of applications.

#### FEATURES

- Lead free product is acquired
- Special process technology for high ESD capability
- High density cell design for ultra low  $R_{DS(on)}$
- Good stability and uniformity with high  $E_{AS}$
- Excellent package for good heat dissipation

#### APPLICATION

- Power switching application
- Hard switching and high frequency circuits
- Uninterruptible power supply

#### MARKING

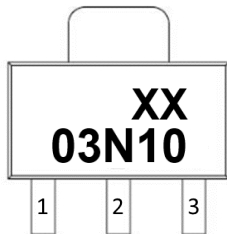

XX: Data Code

#### Equivalent Circuit

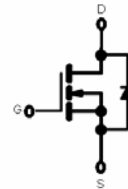

#### Maximum ratings ( $T_a=25^\circ\text{C}$ unless otherwise noted)

Parameter	Symbol	Value	Unit
Drain-Source Voltage	$V_{DS}$	100	V
Gate-Source Voltage	$V_{GS}$	±20	V
Continuous Drain Current	$I_D$	3	A
Pulsed Drain Current ( <b>note 1</b> )	$I_{DM}$	20	A
Power Dissipation	$P_D$	0.5	W
Thermal Resistance from Junction to Ambient ( <b>note 2</b> )	$R_{\theta JA}$	250	$^\circ\text{C/W}$
Junction Temperature	$T_J$	150	$^\circ\text{C}$
Storage Temperature	$T_{STG}$	-55~+150	$^\circ\text{C}$



## MOSFET ELECTRICAL CHARACTERISTICS

$T_a=25^\circ\text{C}$  unless otherwise specified

Parameter	Symbol	Test Condition	Min	Typ	Max	Unit
<b>STATIC CHARACTERISTICS</b>						
Drain-source breakdown voltage	$V_{(BR)DSS}$	$V_{GS} = 0V, I_D = 250\mu A$	100			V
Zero gate voltage drain current	$I_{DSS}$	$V_{DS} = 100V, V_{GS} = 0V$			1	$\mu A$
Gate-body leakage current	$I_{GSS}$	$V_{GS} = \pm 20V, V_{DS} = 0V$			$\pm 100$	nA
Gate threshold voltage (note 3)	$V_{GS(th)}$	$V_{DS} = V_{GS}, I_D = 250\mu A$	1	1.6	3	V
Drain-source on-resistance (note 3)	$R_{DS(on)}$	$V_{GS} = 10V, I_D = 3A$		113	140	$m\Omega$
		$V_{GS} = 4.5V, I_D = 2A$		125	190	$m\Omega$
Forward transconductance (note 3)	$g_{FS}$	$V_{DS} = 5V, I_D = 2.9A$	3			S
Diode forward voltage (note 3)	$V_{SD}$	$I_S = 3A, V_{GS} = 0V$			1.2	V
<b>DYNAMIC CHARACTERISTICS (note 4)</b>						
Input capacitance	$C_{iss}$	$V_{DS} = 25V, V_{GS} = 0V, f = 1MHz$		607		pF
Output capacitance	$C_{oss}$			38		pF
Reverse transfer capacitance	$C_{riss}$			20		pF
<b>SWITCHING CHARACTERISTICS (note 4)</b>						
Turn-on delay time	$t_{d(on)}$	$V_{GS} = 10V, V_{DS} = 30V,$ $R_{GEN} = 2.5\Omega, I_D = 2A, R_L = 15\Omega$		9.7		ns
Turn-on rise time	$t_r$			6.5		ns
Turn-off delay time	$t_{d(off)}$			31		ns
Turn-off fall time	$t_f$			8		ns
Total gate charge	$Q_g$	$V_{DS} = 30V, V_{GS} = 10V, I_D = 3A$		13.7		nC
Gate-source Charge	$Q_{gs}$			3.1		nC
Gate-drain Charge	$Q_{gd}$			4.5		nC

**Notes :**

1. Repetitive rating : Pulse width limited by junction temperature.
2. Surface mounted on FR4 board ,  $t \leq 10s$ .
3. Pulse Test : Pulse Width  $\leq 300\mu s$ , Duty Cycle  $\leq 2\%$ .
4. Guaranteed by design, not subject to producing.

## Typical Characteristics

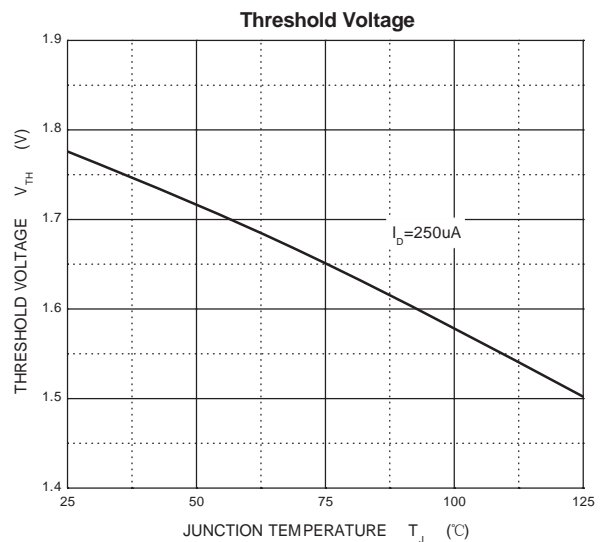
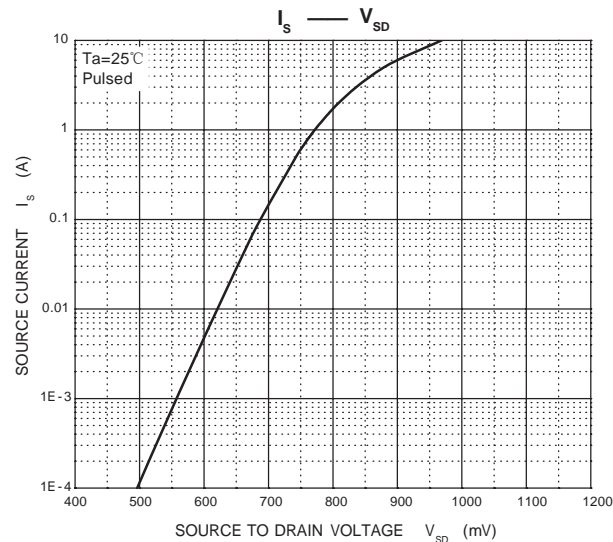
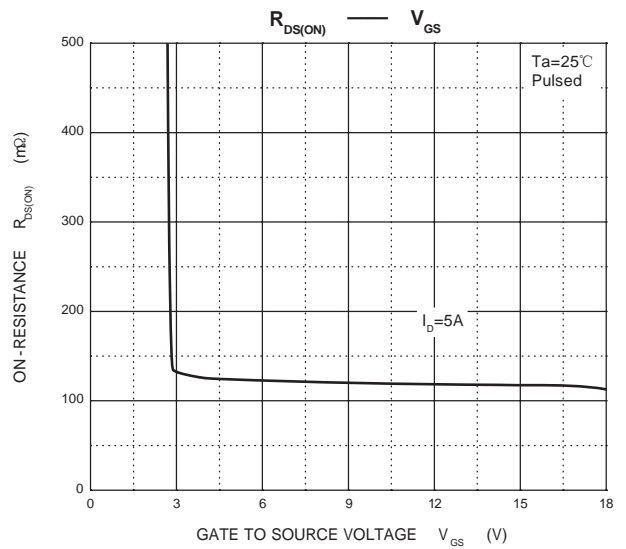
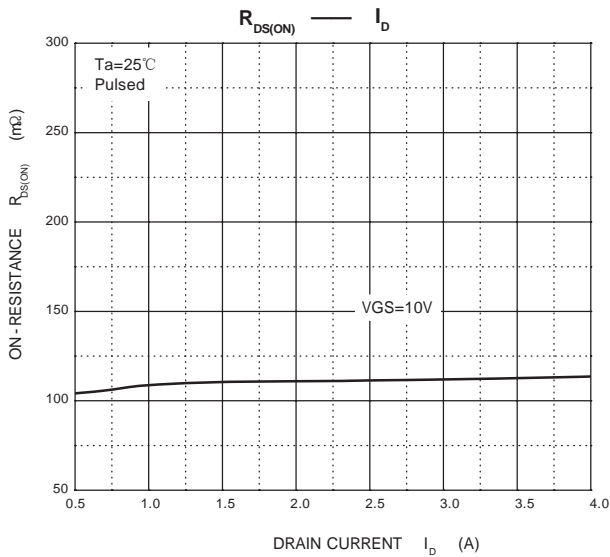
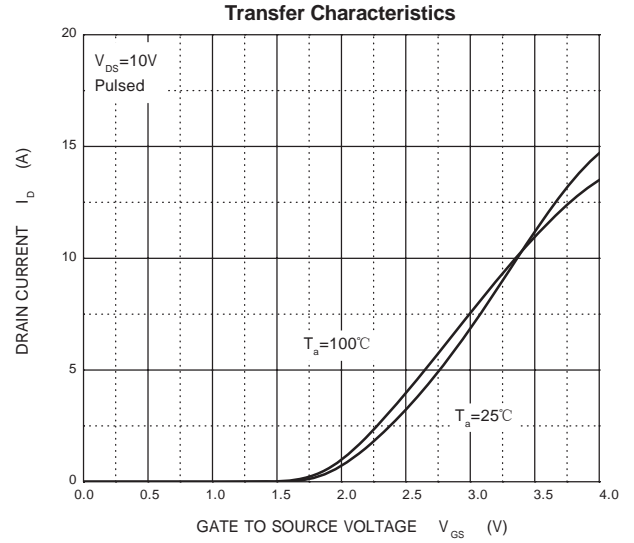
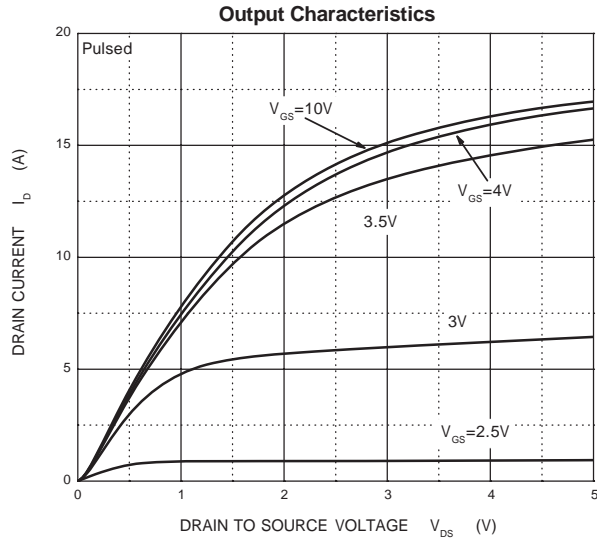

## SOT-89-3L Package Outline Dimensions

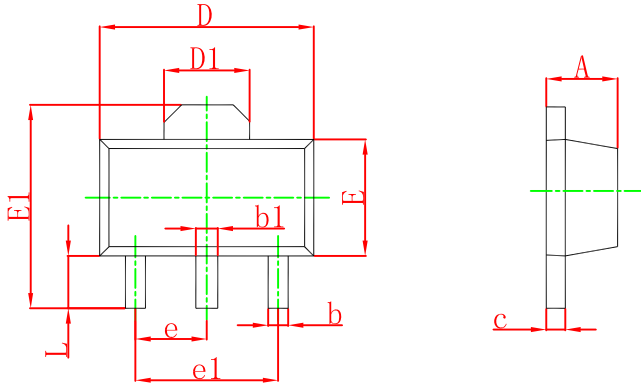

Symbol	Dimensions In Millimeters		Dimensions In Inches	
	Min	Max	Min	Max
A	1.400	1.600	0.055	0.063
b	0.320	0.520	0.013	0.020
b1	0.400	0.580	0.016	0.023
c	0.350	0.440	0.014	0.017
D	4.400	4.600	0.173	0.181
D1	1.550 REF.		0.061 REF.	
E	2.300	2.600	0.091	0.102
E1	3.940	4.250	0.155	0.167
e	1.500 TYP.		0.060 TYP.	
e1	3.000 TYP.		0.118 TYP.	
L	0.900	1.200	0.035	0.047

## SOT-89-3L Suggested Pad Layout

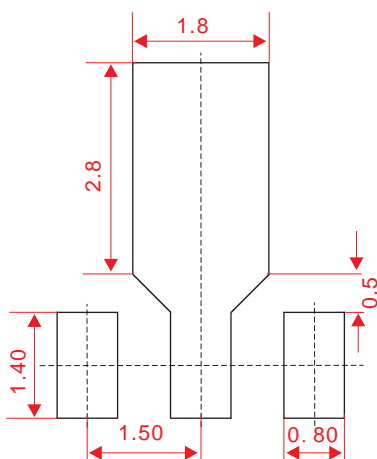

**Note:**

1. Controlling dimension: in millimeters.
2. General tolerance:  $\pm 0.05$ mm.
3. The pad layout is for reference purposes only.

## SOT-89-3L Tape and Reel

### SOT-89-3L Embossed Carrier Tape

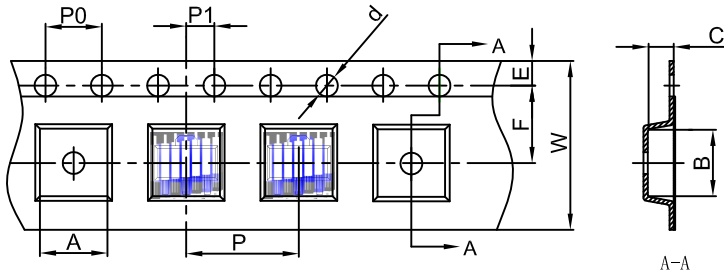

#### Packaging Description:

SOT-89-3L parts are shipped in tape. The carrier tape is made from a dissipative (carbon filled) polycarbonate resin. The cover tape is a multilayer film (Heat Activated Adhesive in nature) primarily composed of polyester film, adhesive layer, sealant, and anti-static sprayed agent. These reeled parts in standard option are shipped with 1,000 units per 7" or 18.0 cm diameter reel. The reels are clear in color and is made of polystyrene plastic (anti-static coated).

Dimensions are in millimeter										
Pkg type	A	B	C	d	E	F	P0	P	P1	W
SOT-89-3L	4.85	4.45	1.85	Ø1.50	1.75	5.50	4.00	8.00	2.00	12.00

### SOT-89-3L Tape Leader and Trailer

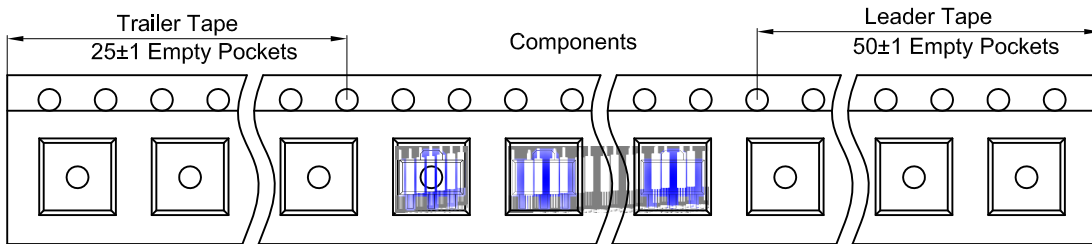

### SOT-89-3L Reel

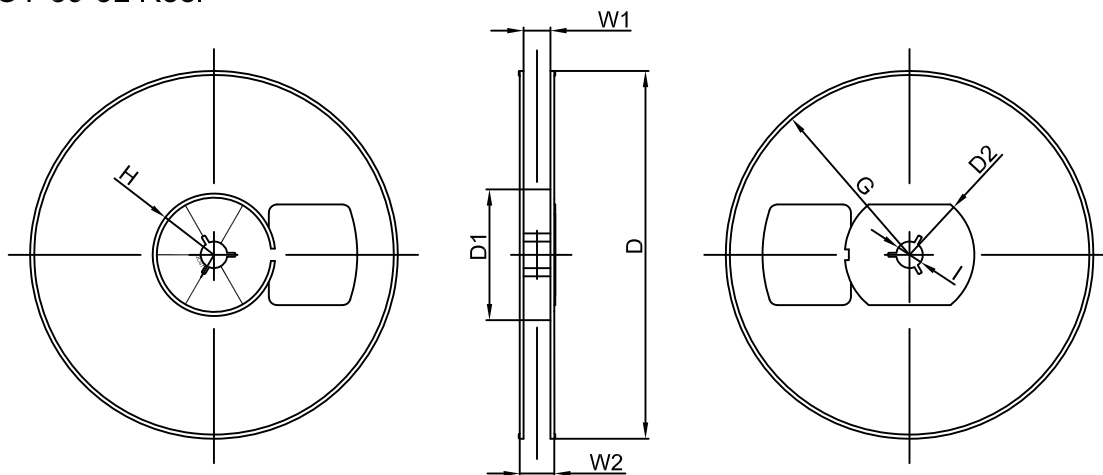

Dimensions are in millimeter								
Reel Option	D	D1	D2	G	H	I	W1	W2
7" Dia	Ø180.00	60.00	R32.00	R86.50	R30.00	Ø13.00	13.20	16.50

REEL	Reel Size	Box	Box Size(mm)	Carton	Carton Size(mm)	G.W.(kg)
1000 pcs	7 inch	10,000 pcs	203×203×195	40,000 pcs	438×438×220	