

600V N-Channel MOS FETs

General Description

These N-Channel enhancement mode power field effect transistors are planar stripe, DMOS technology. This advanced technology has been especially tailored to minimize on-state resistance, provide superior switching performance, and withstand high energy pulse in the avalanche and commutation mode. These devices are well suited for high efficiency switch mode power supply

BVDSS	RDSON	ID
600V	160Ω	0.1A

Features

- Improved dv/dt capability
- Fast switching
- Green Device Available

SOT23-3S Pin Configuration

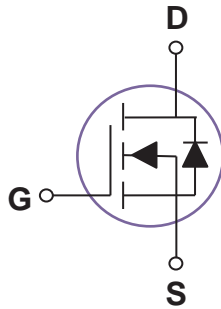
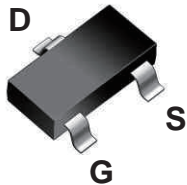

Applications

- High efficient switched mode power supplies
- TV Power
- Adapter/charger
- LED Lighting

Absolute Maximum Ratings $T_c=25^\circ\text{C}$ unless otherwise noted

Symbol	Parameter	Rating	Units
V_{DS}	Drain-Source Voltage	600	V
V_{GS}	Gate-Source Voltage	± 20	V
I_D	Drain Current – Continuous ($T_c=25^\circ\text{C}$)	0.1	A
	Drain Current – Continuous ($T_c=100^\circ\text{C}$)	0.06	A
I_{DM}	Drain Current – Pulsed ¹	0.4	A
P_D	Power Dissipation ($T_c=25^\circ\text{C}$)	1.56	W
	Power Dissipation – Derate above 25°C	0.012	W/ $^\circ\text{C}$
T_{STG}	Storage Temperature Range	-55 to 150	$^\circ\text{C}$
T_J	Operating Junction Temperature Range	-55 to 150	$^\circ\text{C}$

Thermal Characteristics

Symbol	Parameter	Typ.	Max.	Unit
$R_{\theta JA}$	Thermal Resistance Junction to ambient	---	80	$^\circ\text{C}/\text{W}$

Electrical Characteristics (T_J=25°C)

Off Characteristics

Symbol	Parameter	Conditions	Min.	Typ.	Max.	Unit
BV _{DSS}	Drain-Source Breakdown Voltage	V _{GS} =0V , I _D =250uA	600	---	---	V
ΔBV _{DSS} /ΔT _J	BV _{DSS} Temperature Coefficient	Reference to 25°C , I _D =1mA	---	0.52	---	V/°C
I _{DSS}	Drain-Source Leakage Current	V _{DS} =600V , V _{GS} =0V , T _J =25°C	---	---	1	uA
		V _{DS} =480V , V _{GS} =0V , T _J =125°C	---	---	10	uA
I _{GSS}	Gate-Source Leakage Current	V _{GS} =±20V , V _{DS} =0V	---	---	±100	nA

On Characteristics

R _{DS(on)}	Static Drain-Source On-Resistance	V _{GS} =10V , I _D =0.1A	---	90	160	Ω
V _{GS(th)}	Gate Threshold Voltage	V _{GS} =V _{DS} , I _D =250uA	1.5	2.3	3	V
ΔV _{GS(th)}	V _{GS(th)} Temperature Coefficient		---	-3.74	---	mV/°C
g _{fs}	Forward Transconductance	V _{DS} =10V , I _D =0.07A	---	0.7	---	S

Dynamic and switching Characteristics

Q _g	Total Gate Charge ^{2,3}	V _{DS} =480V , V _{GS} =10V , I _D =0.1A	---	2.4	5	nC
Q _{gs}	Gate-Source Charge ^{2,3}		---	0.3	1	
Q _{gd}	Gate-Drain Charge ^{2,3}		---	0.2	1	
T _{d(on)}	Turn-On Delay Time ^{2,3}	V _{DD} =300V , V _{GS} =10V , R _G =3.3Ω I _D =0.05A	---	9.2	18	ns
T _r	Rise Time ^{2,3}		---	12.2	24	
T _{d(off)}	Turn-Off Delay Time ^{2,3}		---	14.4	28	
T _f	Fall Time ^{2,3}		---	76.8	150	
C _{iss}	Input Capacitance	V _{DS} =25V , V _{GS} =0V , F=1MHz	---	32.8	65	pF
C _{oss}	Output Capacitance		---	9.7	20	
C _{rss}	Reverse Transfer Capacitance		---	2	4	

Drain-Source Diode Characteristics and Maximum Ratings

Symbol	Parameter	Conditions	Min.	Typ.	Max.	Unit
I _S	Continuous Source Current	V _G =V _D =0V , Force Current	---	---	0.1	A
I _{SM}	Pulsed Source Current		---	---	0.4	A
V _{SD}	Diode Forward Voltage	V _{GS} =0V , I _S =0.1A , T _J =25°C	---	---	1	V

Note :

1. Repetitive Rating : Pulsed width limited by maximum junction temperature.
2. The data tested by pulsed , pulse width ≤ 300us , duty cycle ≤ 2%.
3. Essentially independent of operating temperature.

ELECTRICAL CHARACTERISTICS CURVES

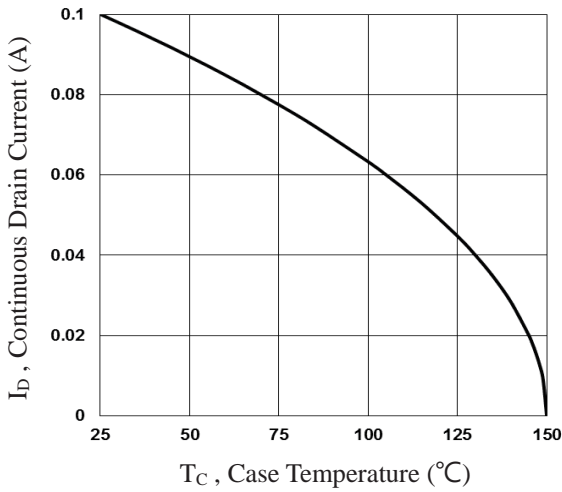

Fig.1 Continuous Drain Current vs. T_c

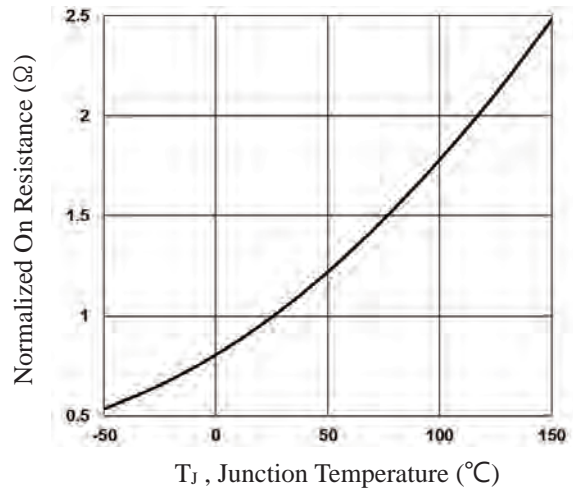

Fig.2 Normalized RDSON vs. T_j

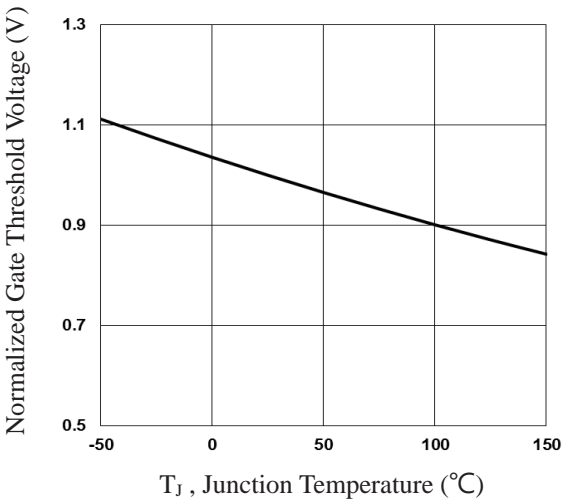

Fig.3 Normalized V_{th} vs. T_j

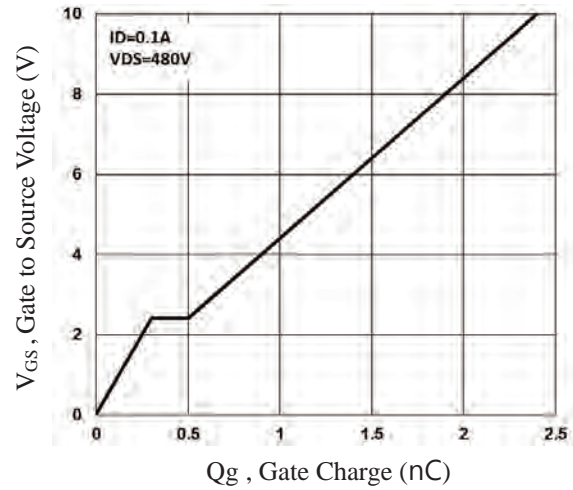

Fig.4 Gate Charge Waveform

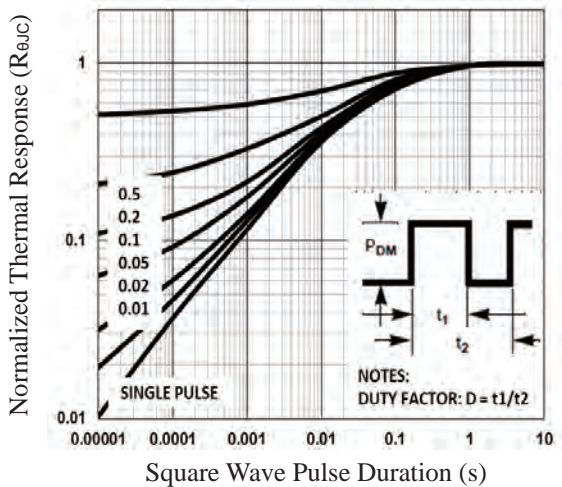

Fig.5 Normalized Transient Impedance

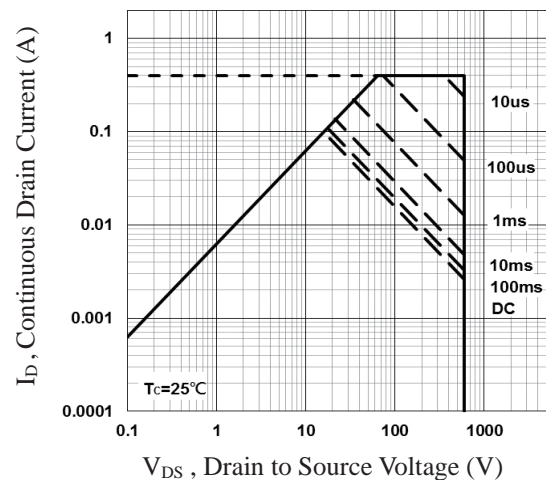

Fig.6 Maximum Safe Operation Area

ELECTRICAL CHARACTERISTICS CURVES (Con.)

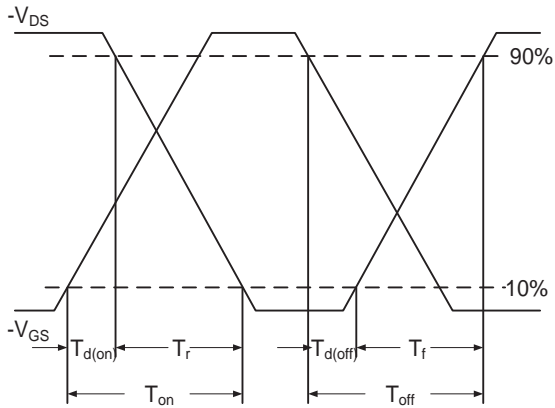

Fig.7 Switching Time Waveform

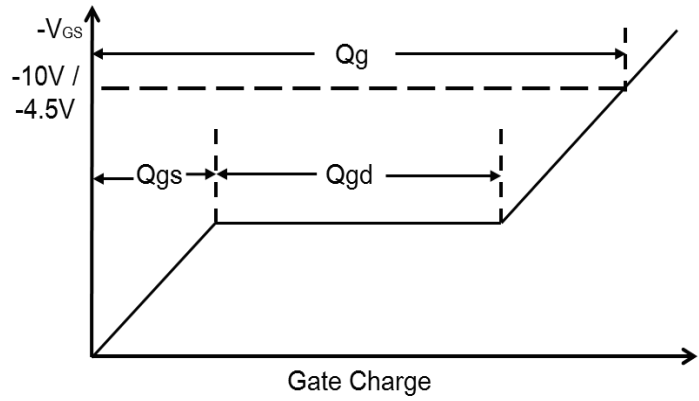
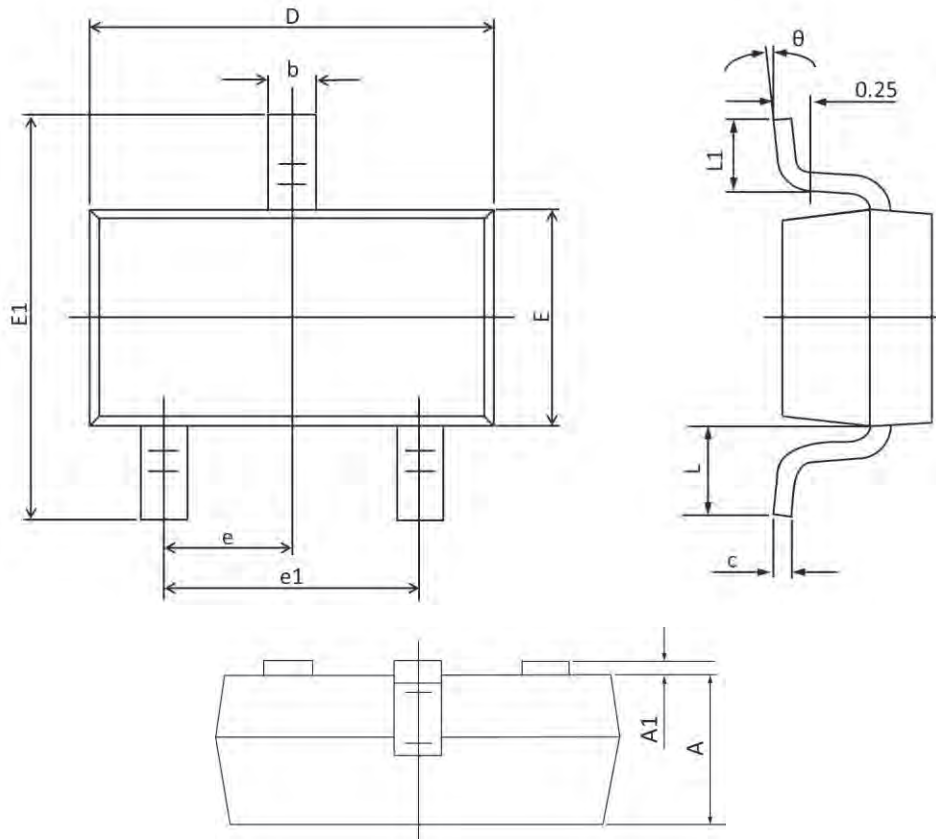

Fig.8 Gate Charge Waveform



Symbol	Dimensions In Millimeters		Dimensions In Inches	
	Min	Max	Min	Max
A	0.900	1.000	0.035	0.039
A1	0.000	0.100	0.000	0.004
b	0.300	0.500	0.012	0.020
c	0.090	0.110	0.003	0.004
D	2.800	3.000	0.110	0.118
E	1.200	1.400	0.047	0.055
E1	2.250	2.550	0.089	0.100
e	0.950 TYP.		0.037 TYP.	
e1	1.800	2.000	0.071	0.079
L	0.550 REF.		0.022 REF.	
L1	0.300	0.500	0.012	0.020
θ	1°	7°	1°	7°