

### Power MOSFET

## 4 Amps, 600 Volt

## N-CHANNEL POWER MOSFET

### DESCRIPTION

The FTK 4N60 is a high voltage MOSFET and is designed to have better characteristics, such as fast switching time, low gate charge, low on-state resistance and have a high rugged avalanche characteristics. This power MOSFET is usually used at high speed switching applications in power supplies, PWM motor controls, high efficient DC to DC converters and bridge circuits.

### FEATURES

- \*  $R_{DS(ON)} = 2.5\Omega @ V_{GS} = 10V$
- \* Ultra low gate charge ( typical 10 nC )
- \* Low reverse transfer Capacitance (  $C_{RSS} = \text{typical } 7.5 \text{ pF}$  )
- \* Fast switching capability
- \* Avalanche energy Specified
- \* Improved dv/dt capability, high ruggedness

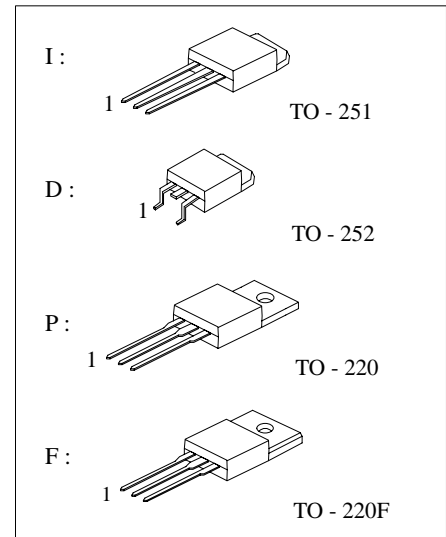

### SYMBOL

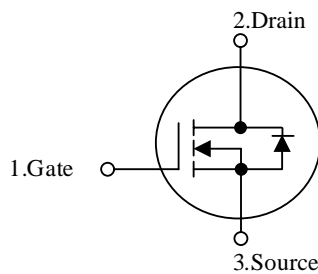

### ORDERING INFORMATION

Ordering Number	Package	Pin Assignment			Packing
		1	2	3	
FTK4N60P	TO-220	G	D	S	Tube
FTK4N60F	TO-220F	G	D	S	Tube
FTK4N60I	TO-251	G	D	S	Tube
FTK4N60D	TO-252	G	D	S	Tape Reel

Note: Pin Assignment: G: Gate D: Drain S: Source

## Power MOSFET

### ■ ABSOLUTE MAXIMUM RATINGS (T<sub>C</sub> = 25°C, unless otherwise specified)

PARAMET		SYMBOL	RATINGS	UNIT
Drain-Source Voltage		V <sub>DSS</sub>	600	V
Gate-Source Voltage		V <sub>GSS</sub>	±30	V
Avalanche Current (Note 1)		I <sub>AR</sub>	4.4	A
Continuous Drain Current	T <sub>C</sub> = 25°C	I <sub>D</sub>	4.0	A
	T <sub>C</sub> = 100°C		2.2	
Pulsed Drain Current (Note 1)		I <sub>DM</sub>	16	A
Avalanche Energy	Single Pulse(Note 2)	E <sub>AS</sub>	150	mJ
	Repetitive Limited by T <sub>J(MAX)</sub>	E <sub>AR</sub>	7.0	mJ
Peak Diode Recovery dv/dt (Note 3)		dv/dt	4.5	V/ns
Power Dissipation		P <sub>D</sub>	106	W
Junction Temperature		T <sub>J</sub>	+150	°C
Operating Temperature		T <sub>OPR</sub>	-55 ~ +150	°C
Storage Temperature		T <sub>STG</sub>	-55 ~ +150	°C

Note: Absolute maximum ratings are those values beyond which the device could be permanently damaged.

Absolute maximum ratings are stress ratings only and functional device operation is not implied.

### ■ ELECTRICAL CHARACTERISTICS (T<sub>C</sub> = 25°C, unless Otherwise specified.)

PARAMETER		SYMBOL	TEST CONDITIONS	MIN	TYP	MAX	UNIT	
<b>OFF CHARACTERISTICS</b>								
Drain-Source Breakdown Voltage		BV <sub>DSS</sub>	V <sub>GS</sub> = 0V, I <sub>D</sub> = 250μA	600			V	
Drain-Source Leakage Current		I <sub>DSS</sub>	V <sub>DS</sub> = 600V, V <sub>GS</sub> = 0V			1	μA	
			V <sub>DS</sub> = 480V, T <sub>C</sub> = 125°C			10	μA	
Gate-Source Leakage Current	Forward	I <sub>GSS</sub>	V <sub>GS</sub> = 30V, V <sub>DS</sub> = 0V			100	nA	
	Reverse		V <sub>GS</sub> = -30V, V <sub>DS</sub> = 0V			-100	nA	
Breakdown Voltage Temperature Coefficient		ΔBV <sub>DSS</sub> / ΔT <sub>J</sub>	I <sub>D</sub> = 250μA, Referenced to 25°C		0.7		V / °C	
<b>ON CHARACTERISTICS</b>								
Gate Threshold Voltage		V <sub>GS(TH)</sub>	V <sub>DS</sub> = V <sub>GS</sub> , I <sub>D</sub> = 250μA	2.0		4.0	V	
Drain-Source On-State Resistance		R <sub>DS(ON)</sub>	V <sub>GS</sub> = 10V, I <sub>D</sub> = 2.2A			2.5	Ω	
Forward Transconductance		g <sub>FS</sub>	V <sub>DS</sub> = 50V, I <sub>D</sub> = 2.2A (Note 4)		1.9		S	
<b>DYNAMIC CHARACTERISTICS</b>								
Input Capacitance		C <sub>ISS</sub>	V <sub>DS</sub> = 25V, V <sub>GS</sub> = 0V, f = 1.0MHz		520		pF	
Output Capacitance		C <sub>OSS</sub>				35		pF
Reverse Transfer Capacitance		C <sub>RSS</sub>				7.5		pF
<b>SWITCHING CHARACTERISTICS</b>								
Turn-On Delay Time		t <sub>D(ON)</sub>	V <sub>DD</sub> = 300V, I <sub>D</sub> = 4A, R <sub>G</sub> = 25Ω (Note 4,5)		10		ns	
Turn-On Rise Time		t <sub>r</sub>				42		ns
Turn-Off Delay Time		t <sub>D(OFF)</sub>				38		ns
Turn-Off Fall Time		t <sub>f</sub>				46		ns
Total Gate Charge		Q <sub>G</sub>	V <sub>DS</sub> = 480V, I <sub>D</sub> = 4A, V <sub>GS</sub> = 10V (Note 4,5)		15		nC	
Gate-Source Charge		Q <sub>GS</sub>				2.8		nC
Gate-Drain Charge		Q <sub>GD</sub>				5.5		nC



### ■ ELECTRICAL CHARACTERISTICS(Cont.)

PARAMETER	SYMBOL	TEST CONDITIONS	MIN	TYP	MAX	UNIT
<b>SOURCE-DRAIN DIODE RATINGS AND CHARACTERISTICS</b>						
Drain-Source Diode Forward Voltage	$V_{SD}$	$V_{GS} = 0\text{ V}, I_S = 4.0\text{ A}$			1.4	V
Maximum Continuous Drain-Source Diode Forward Current	$I_S$				4.0	A
Maximum Pulsed Drain-Source Diode Forward Current	$I_{SM}$				16	A
Reverse Recovery Time	$t_{RR}$	$V_{GS} = 0\text{ V}, I_S = 4.0\text{ A},$		310		ns
Reverse Recovery Charge	$Q_{RR}$	$di/dt = 100\text{ A}/\mu\text{s}$ (Note 4)		2.26		$\mu\text{C}$

Note:

1. Repetitive Rating : Pulse width limited by maximum junction temperature
2.  $L = 17\text{mH}, I_{AS} = 4\text{A}, V_{DD} = 50\text{V}, R_G = 25\ \Omega,$  Starting  $T_J = 25^\circ\text{C}$
3.  $I_{SD} \leq 4\text{A}, di/dt \leq 300\text{A}/\mu\text{s}, V_{DD} \leq BV_{DSS},$  Starting  $T_J = 25^\circ\text{C}$
4. Pulse Test: Pulse width  $\leq 300\mu\text{s},$  Duty cycle  $\leq 2\%$
5. Essentially independent of operating temperature

## TEST CIRCUITS AND WAVEFORMS

## Power MOSFET

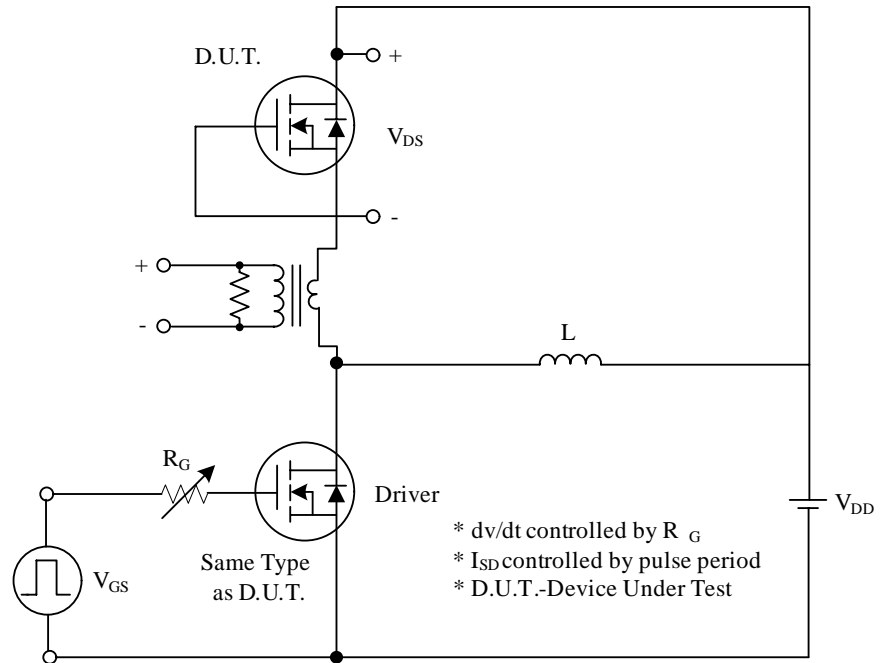

Fig. 1A Peak Diode Recovery  $dv/dt$  Test Circuit

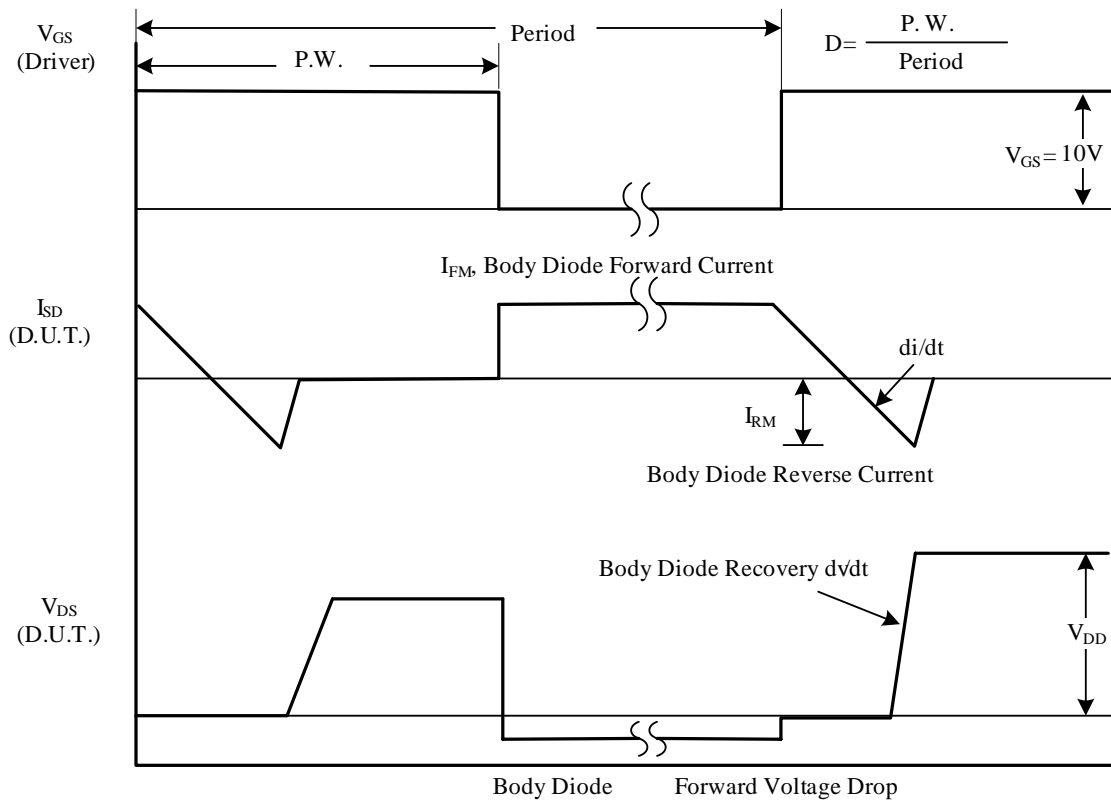

Fig. 1B Peak Diode Recovery  $dv/dt$  Waveforms

## TEST CIRCUITS AND WAVEFORMS (Cont.)

## Power MOSFET

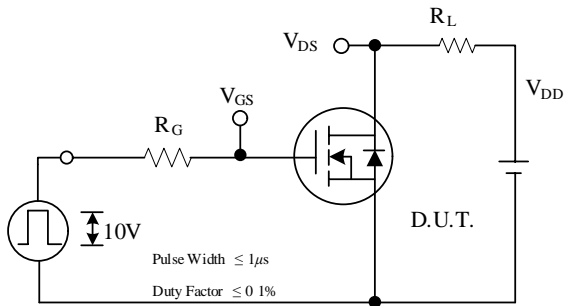

Fig. 2A Switching Test Circuit

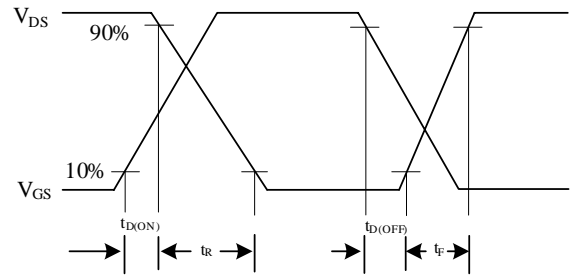

Fig. 2B Switching Waveforms

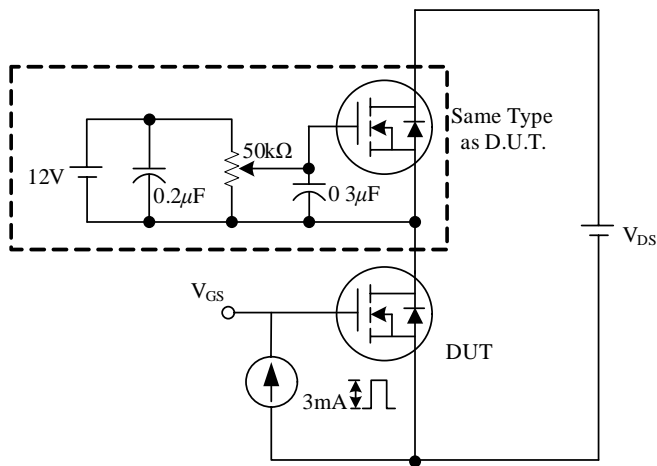

Fig. 3A Gate Charge Test Circuit

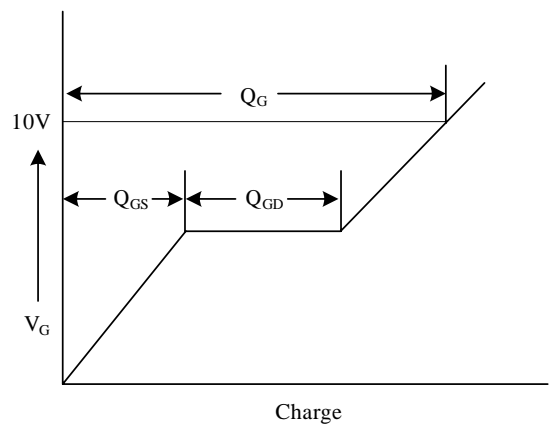

Fig. 3B Gate Charge Waveform

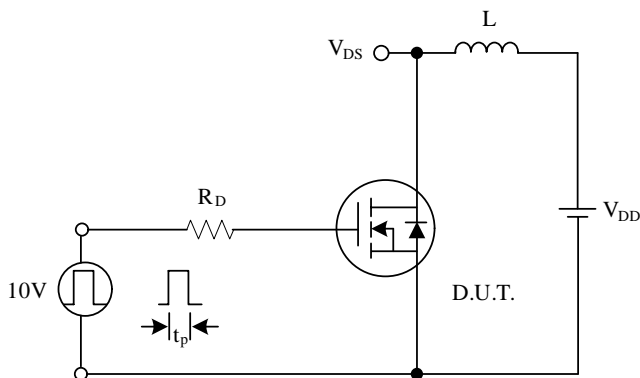

Fig. 4A Unclamped Inductive Switching Test Circuit

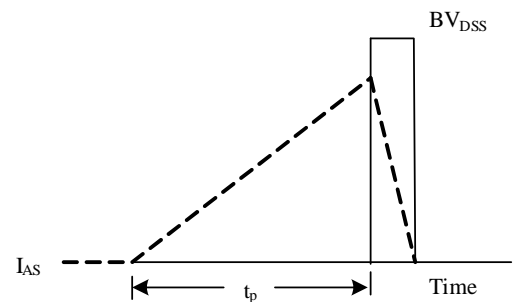
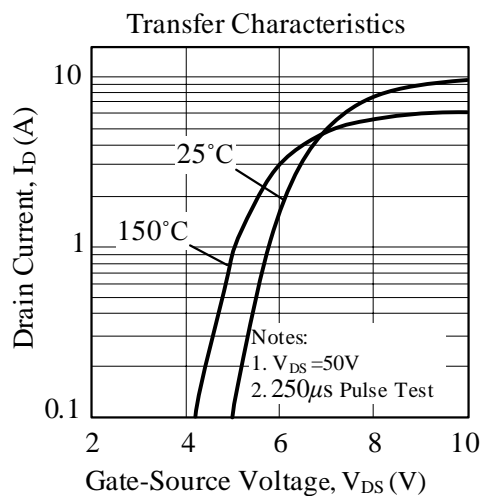
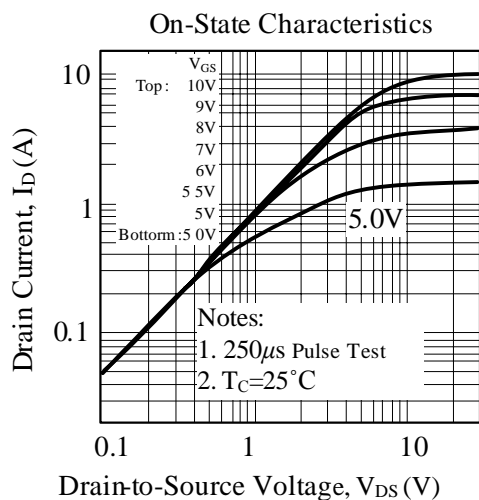
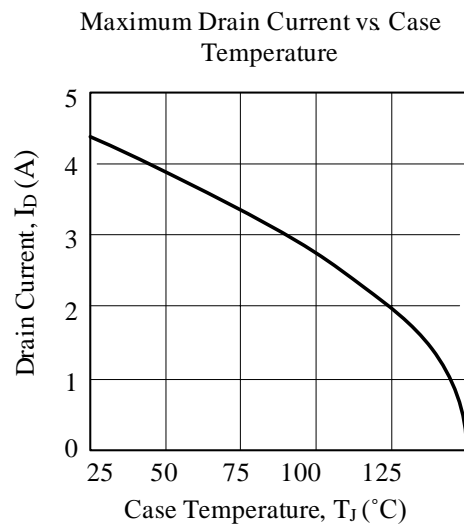
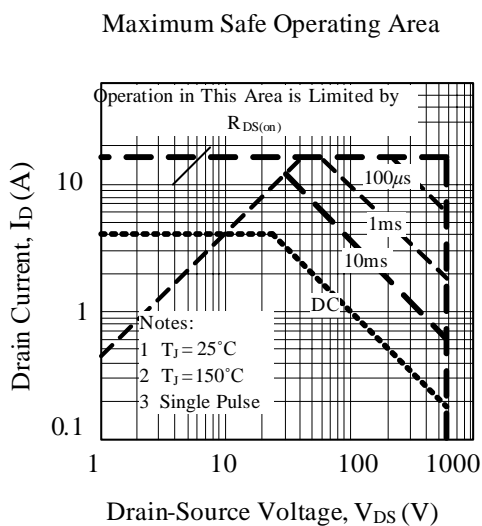
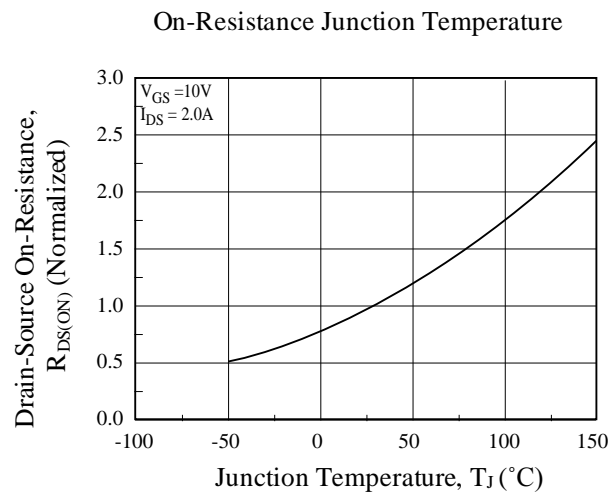
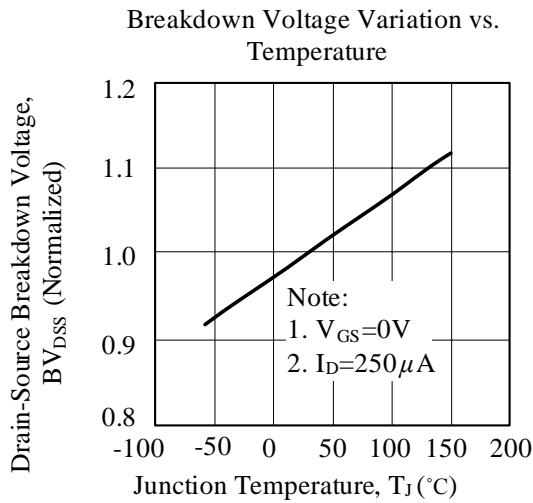

Fig. 4B Unclamped Inductive Switching Waveforms



## TYPICAL CHARACTERISTICS

## Power MOSFET





■ TYPICAL CHARACTERISTICS(Cont.)

On-Resistance Variation vs. Drain Current and Gate Voltage

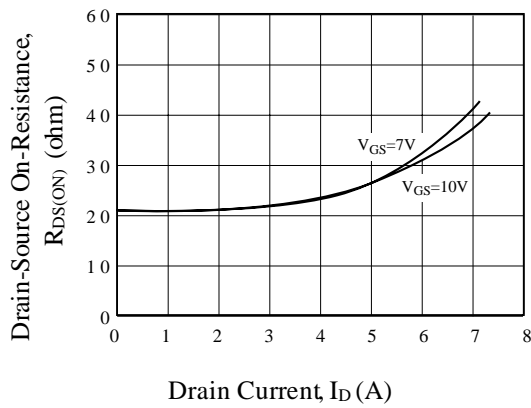

On State Current vs. Allowable Case Temperature

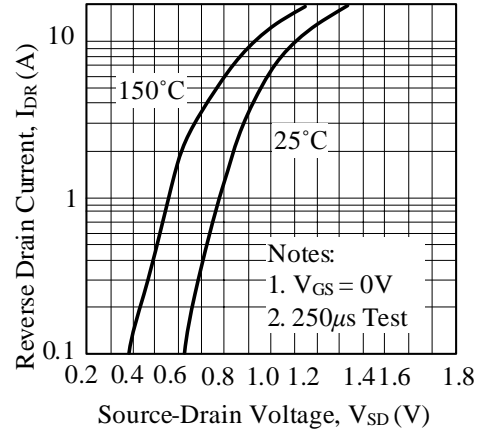

Capacitance Characteristics (Non-Repetitive)

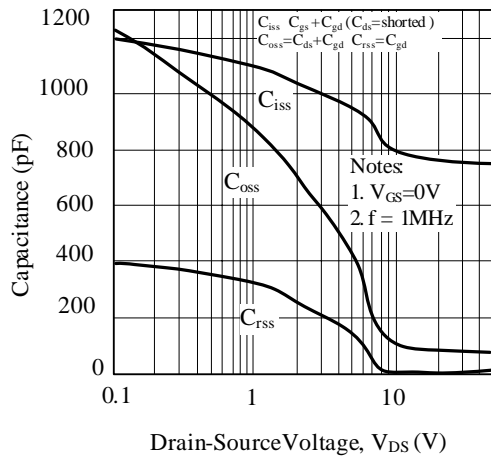

Gate Charge Characteristics

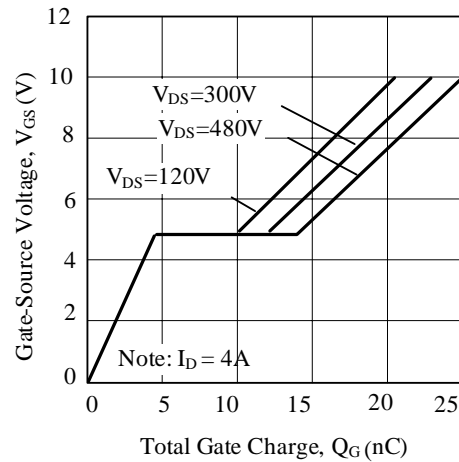

Transient Thermal Response Curve

