



## Bridge Rectifier

### ■ Features

- $I_o$  15A
- $V_{RRM}$  50V~1000V
- High surge forward current capability

### ■ Applications

- General purpose 1 phase Bridge rectifier applications

### ■ Outline Dimensions and Mark

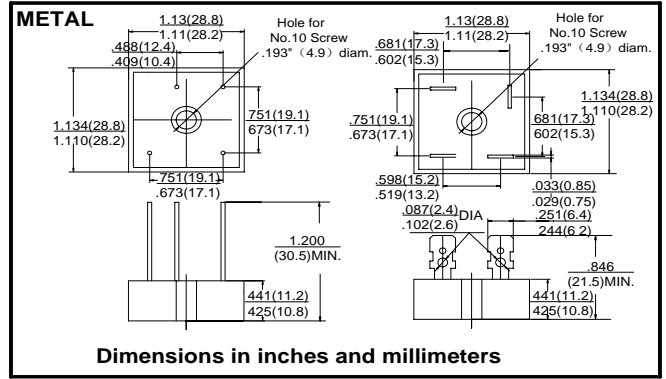

### ■ Limiting Values (Absolute Maximum Rating)

Item	Symbol	Unit	Conditions	KBPC15						
				005	01	02	04	06	08	10
Repetitive Peak Reverse Voltage	$V_{RRM}$	V		50	100	200	400	600	800	1000
Average Rectified Output Current	$I_o$	A	60Hz sine wave, R-load	With heatsink $T_c=55^\circ\text{C}$		15				
Surge(Non-repetitive)Forward Current	$I_{FSM}$	A	60Hz sine wave, 1 cycle, $T_a=25^\circ\text{C}$			300				
Current Squared Time	$I^2t$	$\text{A}^2\text{S}$	$1\text{ms} \leq t < 8.3\text{ms}$ $T_j=25^\circ\text{C}$ , Rating of per diode			375				
Storage Temperature	$T_{stg}$	$^\circ\text{C}$				-55 ~ +150				
Junction Temperature	$T_j$	$^\circ\text{C}$				-55 ~ +125				
Dielectric Strength	$V_{dis}$	KV	Terminals to case, AC 1 minute			2.5				
Mounting Torque	TOR	$\text{kg} \cdot \text{cm}$	Recommend torque: 10 $\text{kg} \cdot \text{cm}$			20				

### ■ Electrical Characteristics ( $T_a=25^\circ\text{C}$ Unless otherwise specified)

Item	Symbol	Unit	Test Condition	Max
Peak Forward Voltage	$V_{FM}$	V	$I_{FM}=7.5\text{A}$ , Pulse measurement, Rating of per	1.1
Peak Reverse Current	$I_{RRM}$	$\mu\text{A}$	$V_{RM}=V_{RRM}$ , Pulse measurement, Rating of per diode	10
Thermal Resistance	$R_{\theta\text{-JC}}$	$^\circ\text{C/W}$	Between junction and case, With heatsink	2.3



### ■ Characteristics(Typical)

