

Plastic-Encapsulate Diodes

FDR520-1006 SCHOTTKY BARRIER DIODE

FEATURE

- Small surface mounting type
- Low reverse current and low forward voltage
- High reliability

APPLICATION

- High speed switching for detection
- For portable equipment:(i.e. Mobile phone,MP3, MD,CD-ROM, DVD-ROM, Note book PC, etc.)

MARKING: E

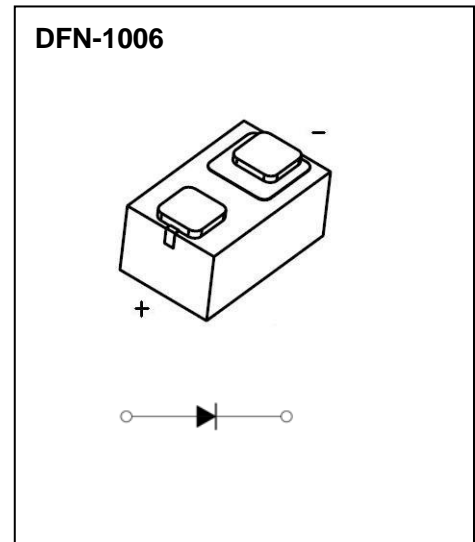

MAXIMUM RATINGS ($T_a=25^{\circ}\text{C}$ unless otherwise noted)

Symbol	Parameter	Limit	Unit
V_{RRM}	Repetitive Peak Reverse Voltage	30	V
V_{RWM}	Working Peak Reverse Voltage		
$V_{R(RMS)}$	RMS Reverse Voltage	21	V
I_O	Average Rectified Output Current	200	mA
I_{FSM}	Non-Repetitive Peak Forward Surge Current@ t=8.3ms	0.5	A
P_d	Power Dissipation	100	mW
$R_{\theta JA}$	Thermal Resistance from Junction to Ambient	1000	$^{\circ}\text{C}/\text{W}$
T_J	Junction temperature	125	$^{\circ}\text{C}$
T_{stg}	Storage Temperature	-55 ~ +150	$^{\circ}\text{C}$

ELECTRICAL CHARACTERISTICS ($T_a = 25^{\circ}\text{C}$ unless otherwise specified)

Parameter	Symbol	Test Condition	Min	Typ	Max	Unit
Reverse breakdown voltage	$V_{(BR)}$	$I_R=100\mu\text{A}$	30			V
Reverse current	I_R	$V_R=10\text{V}$			0.5	μA
Forward voltage	V_F	$I_F=10\text{mA}$			0.45	V



FDR520-1006

Typical Characteristics

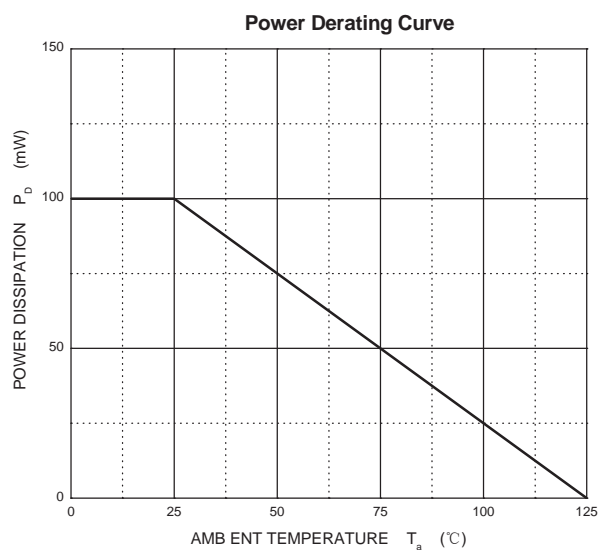
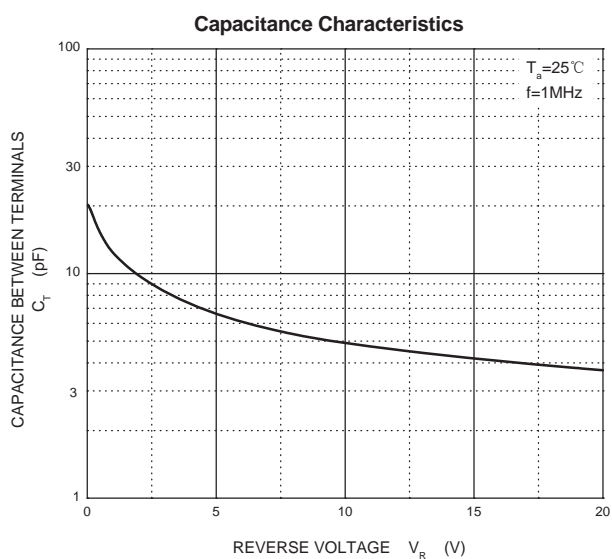
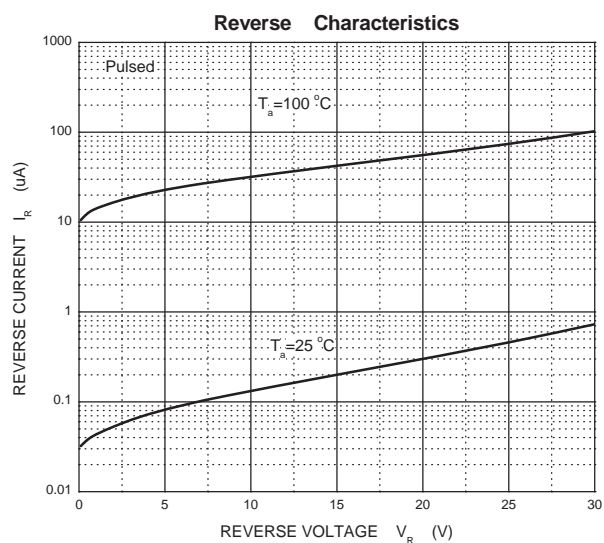
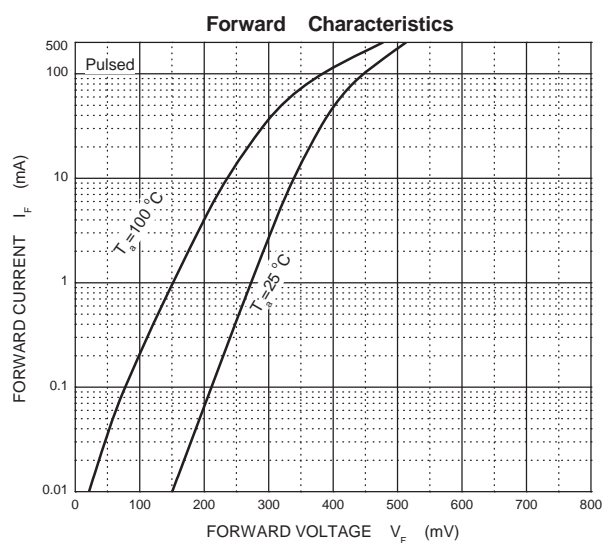

DFN-1006 Package Outline Dimensions

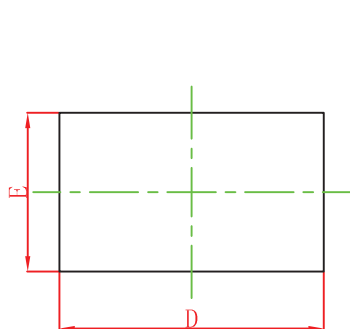

TOP VIEW

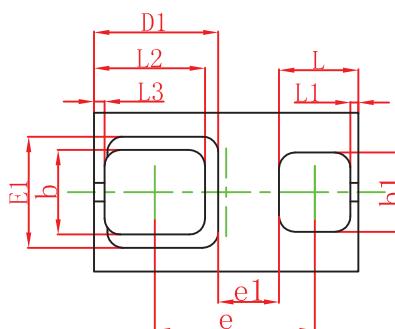

BOTTOM VIEW

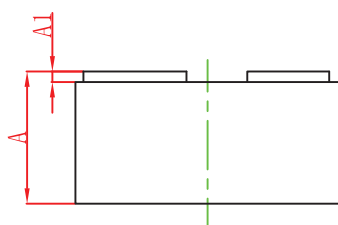

SIDE VIEW

Symbol	Dimensions In Millimeters		Dimensions In Inches	
	Min.	Max.	Min.	Max.
A	0.450	0.550	0.018	0.022
A1	0.010	0.100	0.000	0.004
D	0.950	1.050	0.037	0.041
E	0.550	0.650	0.022	0.026
D1	0.470REF.		0.019REF.	
E1	0.420REF.		0.017REF.	
b	0.270	0.370	0.011	0.015
b1	0.250	0.350	0.010	0.014
e	0.555	0.655	0.022	0.026
e1	0.230REF.		0.009REF.	
L	0.250	0.350	0.010	0.014
L1	0.030REF.		0.001REF.	
L2	0.370	0.470	0.015	0.019
L3	0.040REF.		0.002REF.	

DFN-1006 Suggested Pad Layout

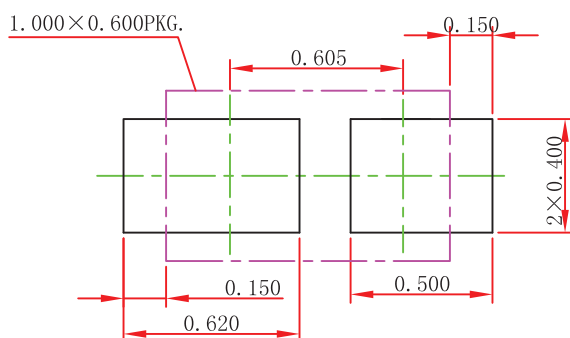

Note:

1. Controlling dimension: in millimeters.
2. General tolerance: $\pm 0.050\text{mm}$.
3. The pad layout is for reference purposes only.

DFN-1006 Tape and Reel

Embossed Carrier Tape

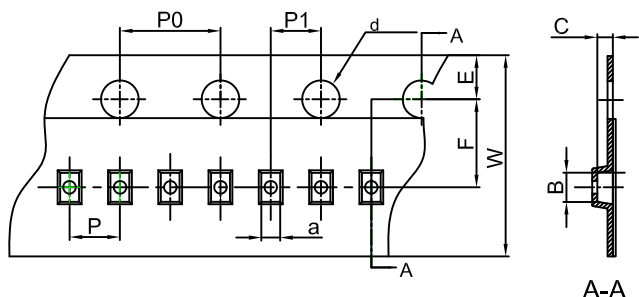

Packaging Description:

DFN-1006 parts are shipped in tape. The carrier tape is made from a dissipative (carbon filled) polycarbonate resin. The cover tape is a multilayer film (Heat Activated Adhesive in nature) primarily composed of polyester film, adhesive layer, sealant, and anti-static sprayed agent. These reeled parts in standard option are shipped with 10,000 units per 7" or 17.8cm diameter reel. The reels are clear in color and is made of polystyrene plastic (anti-static coated).

Dimensions are in millimeter										
Pkg type	a	B	C	d	E	F	P0	P	P1	W
DFN-1006	0.66	1.15	0.66	Ø1.50	1.75	3.50	4.00	2.00	2.00	8.00

Tape Leader and Trailer

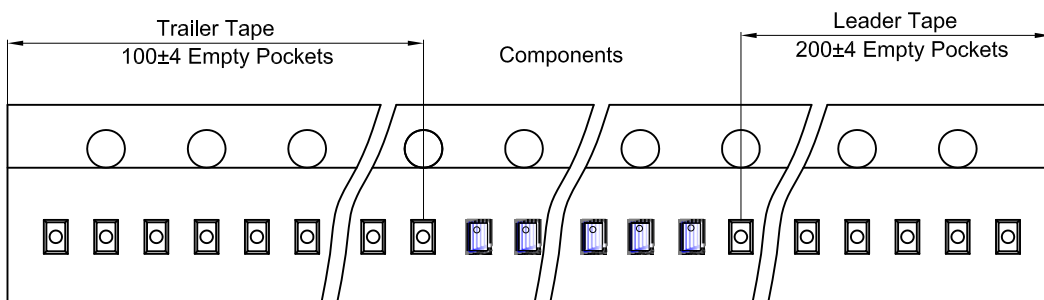

Reel

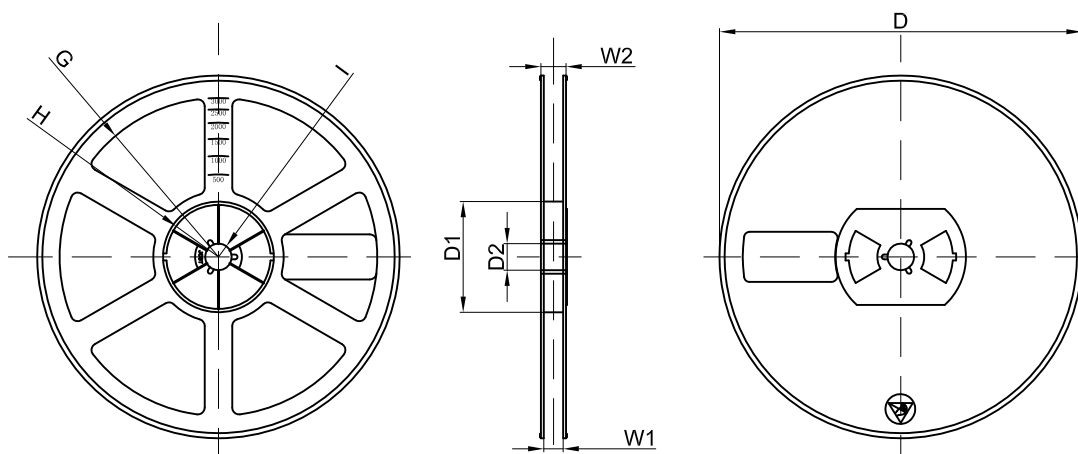

Dimensions are in millimeter								
Reel Option	D	D1	D2	G	H	I	W1	W2
7" Dia	Ø178.00	54.40	13.00	R78.00	R25.60	R6.50	9.50	12.30

REEL	Reel Size	Box	Box Size(mm)	Carton	Carton Size(mm)	G.W.(kg)
10000 pcs	7 inch	150,000 pcs	203×203×195	600,000 pcs	438×438×220	