

Super fast rectifier

Reverse voltage 400 volts forward current 20 ampers

Features

- ◆ Low power loss, high efficiency
- ◆ Low forward voltage, high current capability
- ◆ High surge capacity
- ◆ Super fast recovery times, high voltage

Mechanical Data

- ◆ Case: Full molded plastic package
- ◆ Terminals: Lead solderable per MIL-STD-202, Method 208
- ◆ Polarity: As marked
- ◆ Standard packaging: Any
- ◆ Weight: 0.08 ounces, 2.24 grams

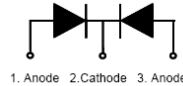
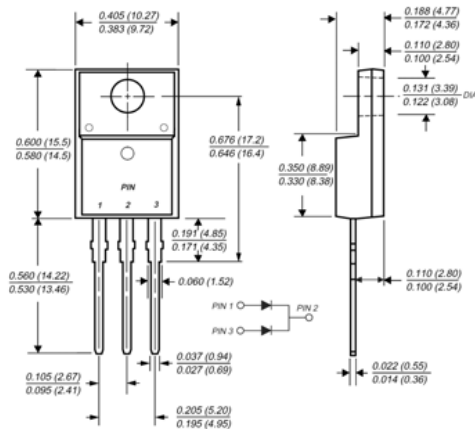
TO-220F

Maximum Ratings and Electrical Characteristics

Ratings at 25°C ambient temperature unless otherwise specified.

Parameter	Symbol	SFF2040CT	Unit
Maximum repetitive peak reverse voltage	V_{RRM}	400	Volts
Maximum RMS voltage	V_{RMS}	400	Volts
Maximum DC blocking voltage	V_{DC}	400	Volts
Maximum average forward rectified current at $T_C=105^\circ\text{C}$	$I_{F(AV)}$	20	Amps
Peak forward surge current 8.3ms single half sine-wave superimposed on rated load (JEDEC Method)	I_{FSM}	125	Amps
Maximum instantaneous forward voltage at 10A per element	V_F	1.3	Volts
Maximum DC reverse current at rated DC blocking voltage @ $T_C=25^\circ\text{C}$ @ $T_C=100^\circ\text{C}$	I_R	10 500	μA
Maximum reverse recovery time at $I_F=0.5\text{A}$, $I_R=1.0\text{A}$, $I_T=0.25\text{A}$	t_{rr}	50	nS
Typical junction capacitance at 4.0V, 1MHz	C_J	62	pF
Typical thermal resistance	$R_{\theta JC}$	TO-220 : 2 TO-220F : 4	$^\circ\text{C/W}$
Operating junction and storage temperature range	T_J, T_{STG}	-55 to +150	$^\circ\text{C}$

Note:

1. Screw mounting with 4-40 screw, where washer diameter is $\leq 4.9\text{mm}$ (0.19")
2. Pulse test: 300 μs pulse width, 1% duty cycle

RATINGS AND CHARACTERISTIC CURVES

($T_A = 25^\circ\text{C}$ unless otherwise noted)

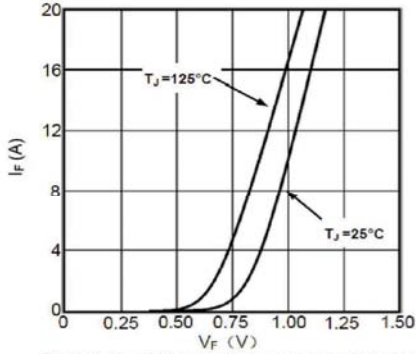

Fig1. Forward Voltage Drop vs Forward Current

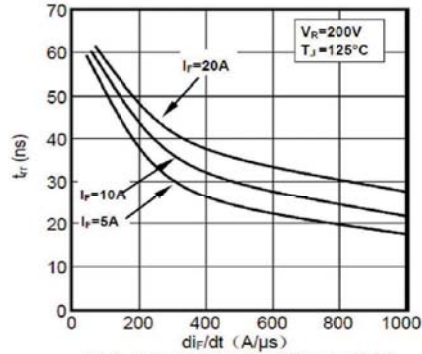

Fig2. Reverse Recovery Time vs di_F/dt

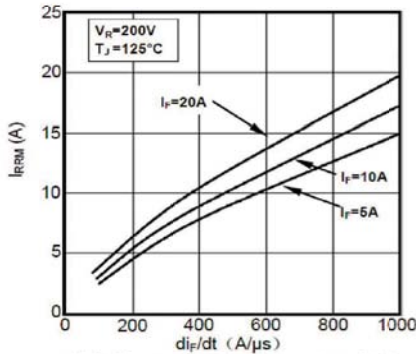

Fig3. Reverse Recovery Current vs di_F/dt

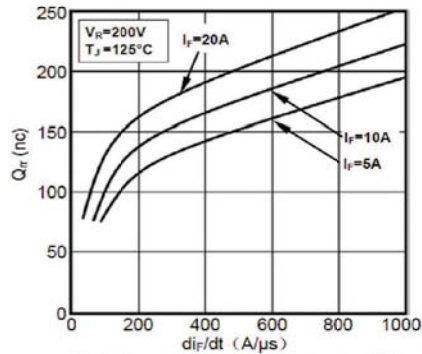

Fig4. Reverse Recovery Charge vs di_F/dt

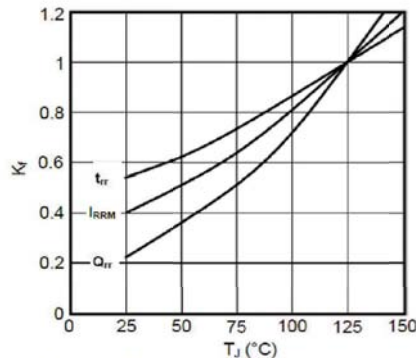

Fig5. Dynamic Parameters vs Junction Temperature

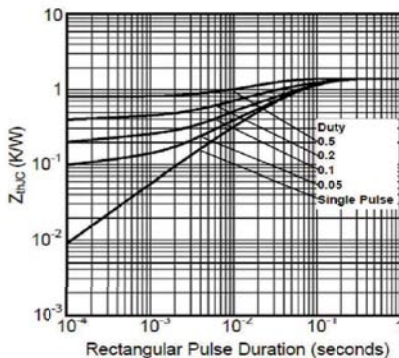

Fig6. Transient Thermal Impedance