

## Surface Mount Schottky Barrier Rectifier

Reverse Voltage - 40 to 200V

Forward Current - 8.0A

### FEATURES

- Metal silicon junction, majority carrier conduction
- For surface mounted applications
- Low power loss, high efficiency
- High forward surge current capability
- For use in low voltage, high frequency inverters, free wheeling, and polarity protection applications

### MECHANICAL DATA

- Case: SMC
- Terminals: Solderable per MIL-STD-750, Method 2026
- Approx. Weight: 0.22g / 0.0077oz

### PINNING

PIN	DESCRIPTION
1	Cathode
2	Anode

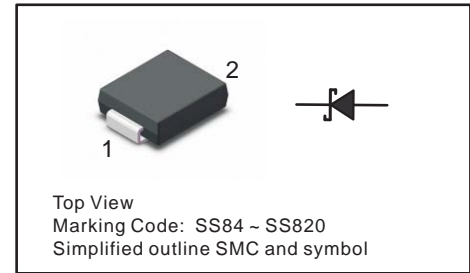

### Absolute Maximum Ratings and Electrical characteristics

Ratings at 25 °C ambient temperature unless otherwise specified. Single phase, half wave, 60Hz resistive or inductive load, for capacitive load, derate by 20 %

Parameter	Symbols	SS84C	SS86C	SS88C	SS810C	SS812C	SS815C	SS820C	Units
Maximum Repetitive Peak Reverse Voltage	$V_{RRM}$	40	60	80	100	120	150	200	V
Maximum RMS voltage	$V_{RMS}$	28	42	56	70	84	105	140	V
Maximum DC Blocking Voltage	$V_{DC}$	40	60	80	100	120	150	200	V
Maximum Average Forward Rectified Current	$I_{F(AV)}$	8.0							A
Peak Forward Surge Current, 8.3ms Single Half Sine-wave Superimposed on Rated Load (JEDEC method)	$I_{FSM}$	150							A
Max Instantaneous Forward Voltage at 8 A	$V_F$	0.55	0.70	0.85					V
Maximum DC Reverse Current $T_a = 25^\circ\text{C}$ at Rated DC Reverse Voltage $T_a = 100^\circ\text{C}$	$I_R$					1.0			mA
						50			
Typical Junction Capacitance <sup>(1)</sup>	$C_j$	900			600				pF
Typical Thermal Resistance <sup>(2)</sup>	$R_{\theta JA}$	35							°C/W
Operating Junction Temperature Range	$T_j$	-55 ~ +150							°C
Storage Temperature Range	$T_{stg}$	-55 ~ +150							°C

( 1 ) Measured at 1 MHz and applied reverse voltage of 4 V D.C

( 2 ) P.C.B. mounted with 2.0" X 2.0" (5 X 5 cm) copper pad areas.

Fig.1 Forward Current Derating Curve

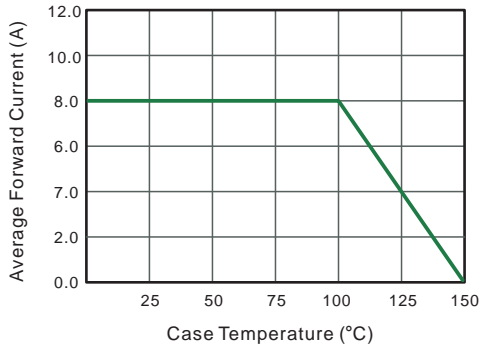

Fig.2 Typical Reverse Characteristics

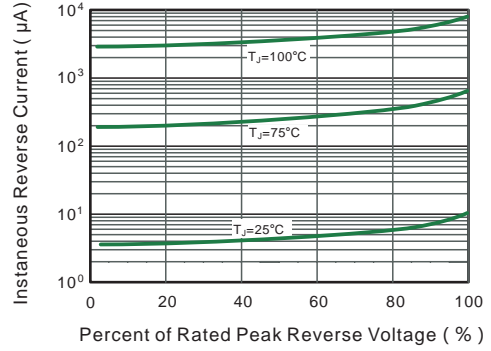

Fig.3 Typical Forward Characteristic

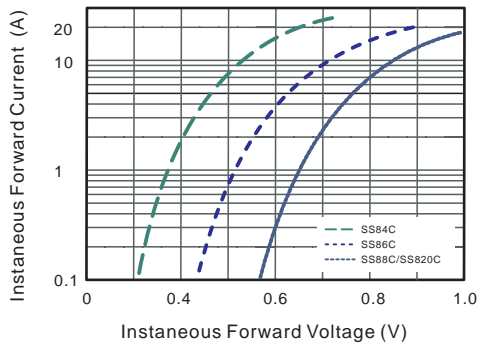

Fig.4 Typical Junction Capacitance

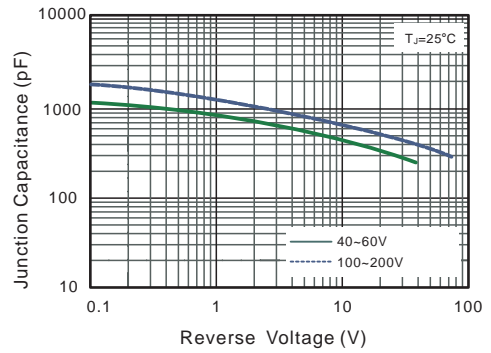

Fig.5 Maximum Non-Repetitive Peak Forward Surge Current

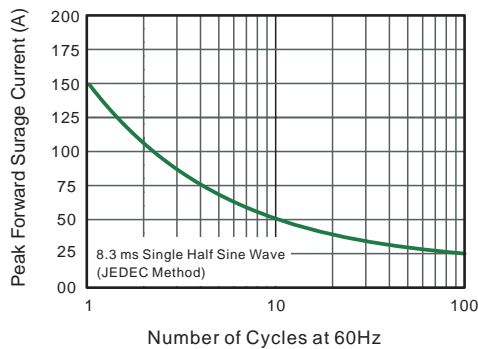
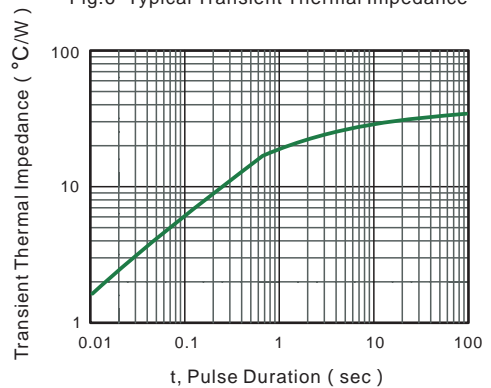

Fig.6 Typical Transient Thermal Impedance



## PACKAGE OUTLINE

Plastic surface mounted package; 2 leads

SMC

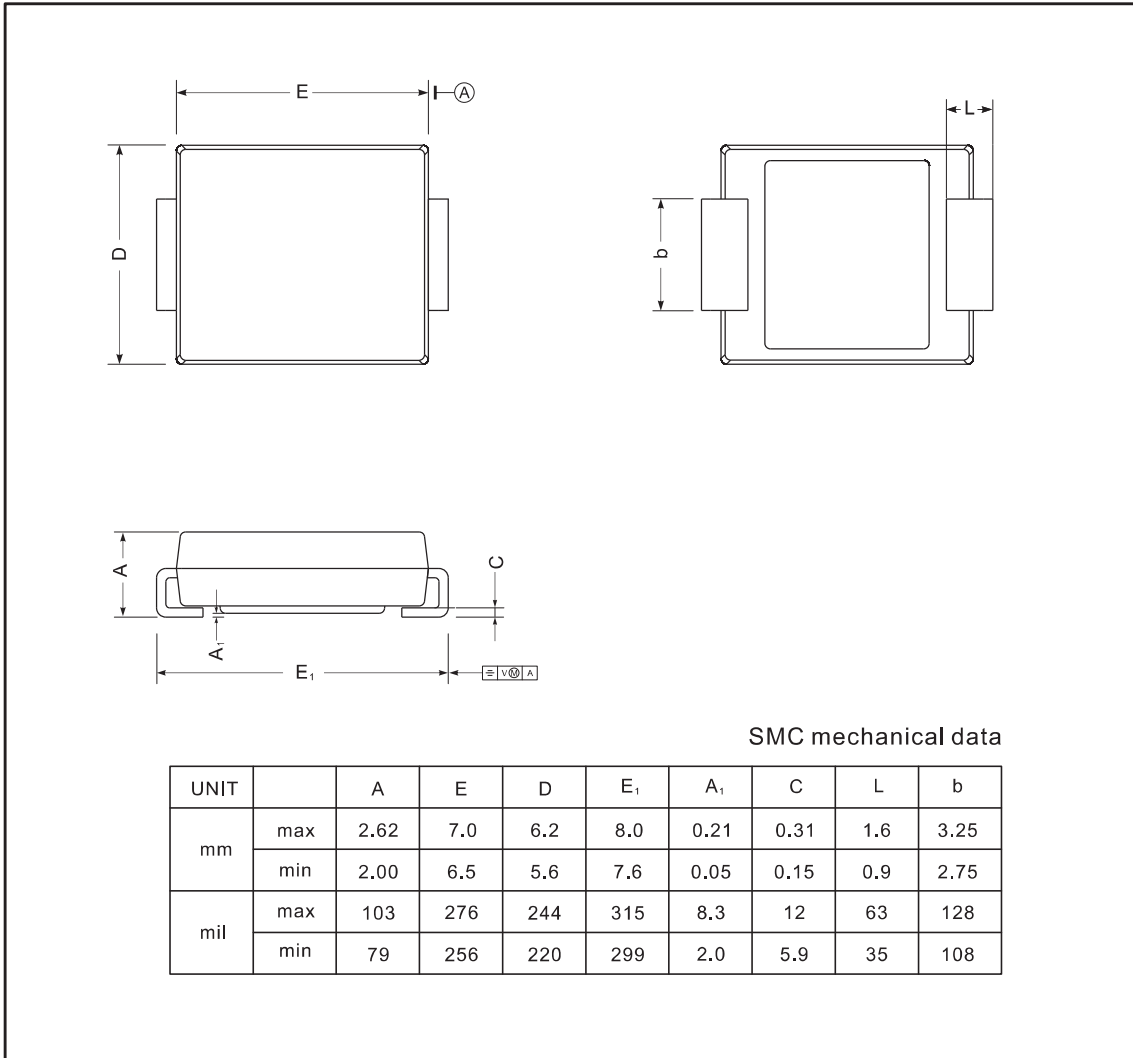

### The recommended mounting pad size

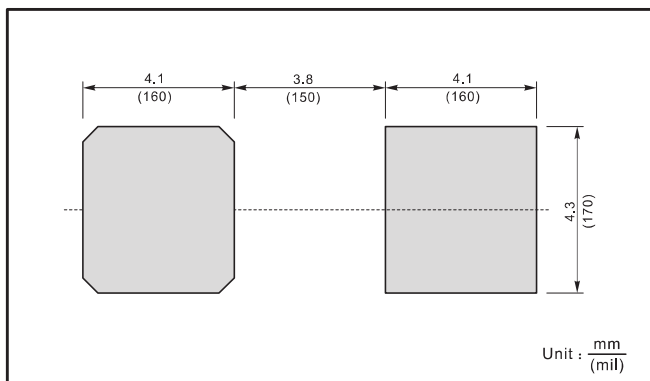

### Marking

Type number	Marking code
SS84C	SS84
SS86C	SS86
SS88C	SS88
SS810C	SS810
SS812C	SS812
SS815C	SS815
SS820C	SS820