

SOD-723 ZENER DIODE

FEATURES

- Planar Die Construction
- 100mW Power Dissipation
- Zener Voltages from 2.4 – 39V

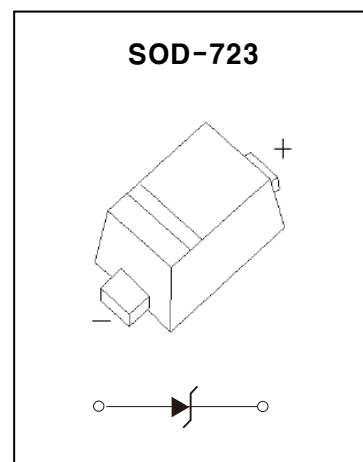

Maximum Ratings @TA=25°C unless otherwise specified

Characteristic	Symbol	Value	Unit
Forward Voltage @I _F =10mA	V _F	0.9	V
Power Dissipation (Note 1)	P _d	100	mW
Thermal Resistance, Junction to Ambient Air	R _{θJA}	1250	°C/W
Junction Temperature	T _j	150	°C
Storage Temperature Range	T _{stg}	-55 ~ +150	°C



FDZ2.4SOD723 ~ FDZ39SOD723

ELECTRICAL CHARACTERISTICS $T_a=25^\circ\text{C}$ unless otherwise specified

Type Number	Type Code	Zener Voltage Range (Note 2)				Maximum Zener Impedance (Note 3)			Maximum Reverse Current		Typical Temperature Coefficient @ $I_{ZT}=5\text{ mA}$ mV/ $^\circ\text{C}$	
		$V_Z@I_{ZT}$			I_{ZT}	$Z_{ZT}@I_{ZT}$	$Z_{ZK}@I_{ZK}$	I_{ZK}	I_R	V_R	Min	Max
		Nom(V)	Min(V)	Max(V)	mA	Ω		mA	μA	V		
FDZ2.3SOD723	Z1	2.2	2.30	2.45	5	100	600	1.0	50	1.0	-3.5	0
FDZ2.7SOD723	Z1	2.4	2.35	2.75	5	100	600	1.0	50	1.0	-3.5	0
FDZ3.0SOD723	Z3	3	2.94	3.06	5	95	600	1.0	10	1.0	-3.5	0
FDZ3.3SOD723	Z4	3.3	3.23	3.37	5	95	600	1.0	5	1.0	-3.5	0
FDZ3.6SOD723	Z5	3.6	3.53	3.67	5	90	600	1.0	5	1.0	-3.5	0
FDZ3.9SOD723	Z6	3.9	3.82	3.98	5	90	600	1.0	3	1.0	-3.5	0
FDZ4.3SOD723	Z7	4.3	4.21	4.39	5	90	600	1.0	3	1.0	-3.5	0
FDZ4.7SOD723	X1	4.7	4.61	4.79	5	80	500	1.0	3	2.0	-3.5	0.2
FDZ5.1SOD723	X2	5.1	5.00	5.20	5	60	480	1.0	2	2.0	-2.7	1.2
FDZ5.6SOD723	X3	5.6	5.49	5.71	5	40	400	1.0	1	2.0	-2.0	2.5
FDZ6.2SOD723	X4	6.2	6.08	6.32	5	10	150	1.0	3	4.0	0.4	3.7
FDZ6.8SOD723	X5	6.8	6.66	6.94	5	15	80	1.0	2	4.0	1.2	4.5
FDZ7.5SOD723	X6	7.5	7.35	7.65	5	15	80	1.0	1	5.0	2.5	5.3
FDZ8.2SOD723	X7	8.2	8.04	8.36	5	15	80	1.0	0.7	5.0	3.2	6.2
FDZ9.1SOD723	X8	9.1	8.92	9.28	5	15	100	1.0	0.5	6.0	3.8	7.0
FDZ10SOD723	X9	10	9.80	10.20	5	20	150	1.0	0.2	7.0	4.5	8.0
FDZ11SOD723	W1	11	10.78	11.22	5	20	150	1.0	0.1	8.0	5.4	9.0
FDZ12SOD723	W2	12	11.76	12.24	5	25	150	1.0	0.1	8.0	6.0	10.0
FDZ13SOD723	W3	13	12.74	13.26	5	30	170	1.0	0.1	8.0	7.0	11.0
FDZ15SOD723	W4	15	14.70	15.30	5	30	200	1.0	0.1	10.5	9.2	13.0
FDZ16SOD723	W5	16	15.68	16.32	5	40	200	1.0	0.1	11.2	10.4	14.0
FDZ18SOD723	W6	18	17.64	18.36	5	45	225	1.0	0.1	12.6	12.4	16.0
FDZ20SOD723	W7	20	19.60	20.40	5	55	225	1.0	0.1	14.0	14.4	18.0
FDZ22SOD723	W8	22	21.56	22.44	5	55	250	1.0	0.1	15.4	16.4	20.0
FDZ24SOD723	W9	24	23.52	24.48	5	70	250	1.0	0.1	16.8	18.4	22.0
FDZ27SOD723	Y1	27	26.46	27.54	2	80	300	0.5	0.1	18.9	21.4	25.3
FDZ30SOD723	Y2	30	29.40	30.60	2	80	300	0.5	0.1	21.0	24.4	29.4
FDZ33SOD723	Y3	33	32.34	33.66	2	80	325	0.5	0.1	23.1	27.4	33.4
FDZ36SOD723	Y4	36	35.28	36.72	2	90	350	0.5	0.1	25.2	30.4	37.4
FDZ39SOD723	Y5	39	38.22	39.78	2	130	350	0.5	0.1	27.3	33.4	41.2

Notes:

1. Valid provided that device terminals are kept at ambient temperature.
2. Tested with pulses, period=5ms,pulse width =300us.
3. $f = 1\text{ KHz}$



FDZ2.4SOD723 ~ FDZ39SOD723

Typical Characteristics

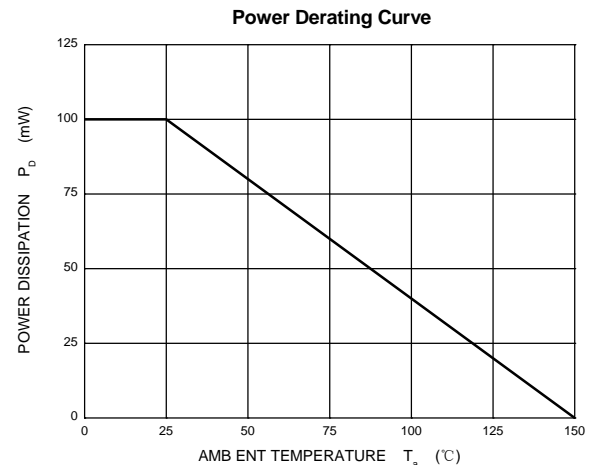
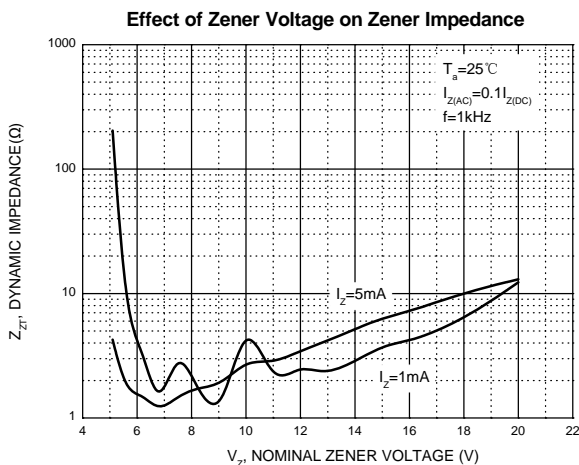
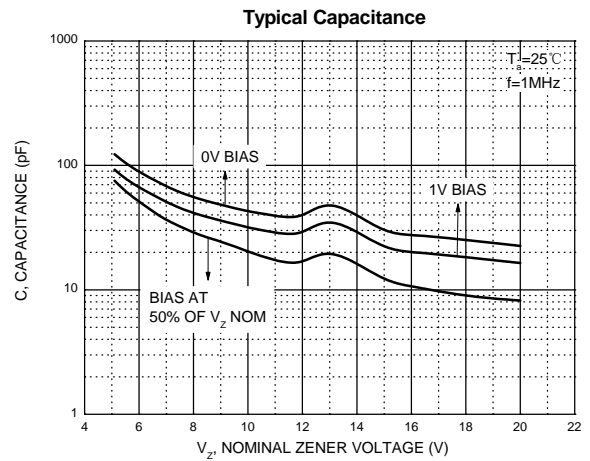
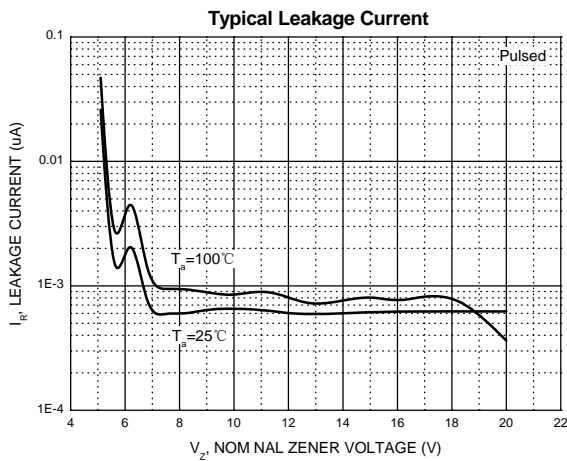
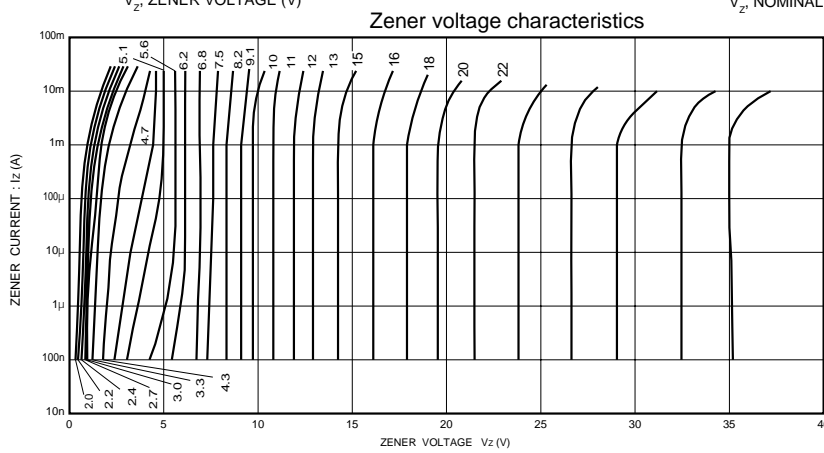
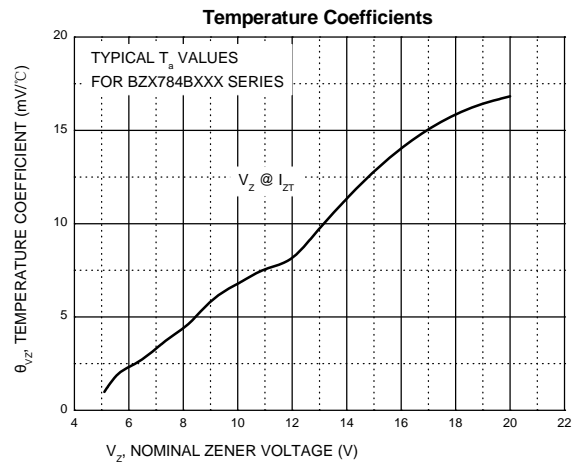
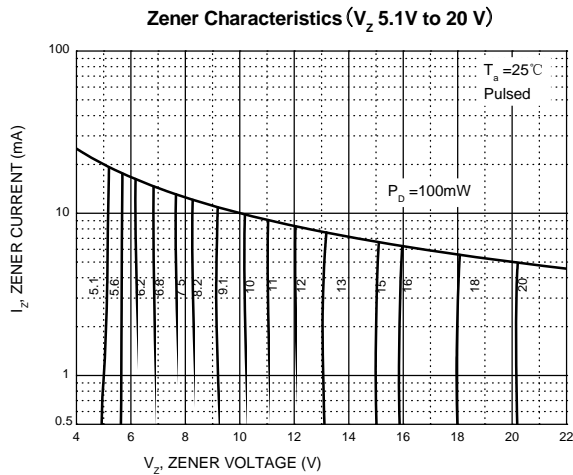

SOD- 723 Package Outline Dimensions

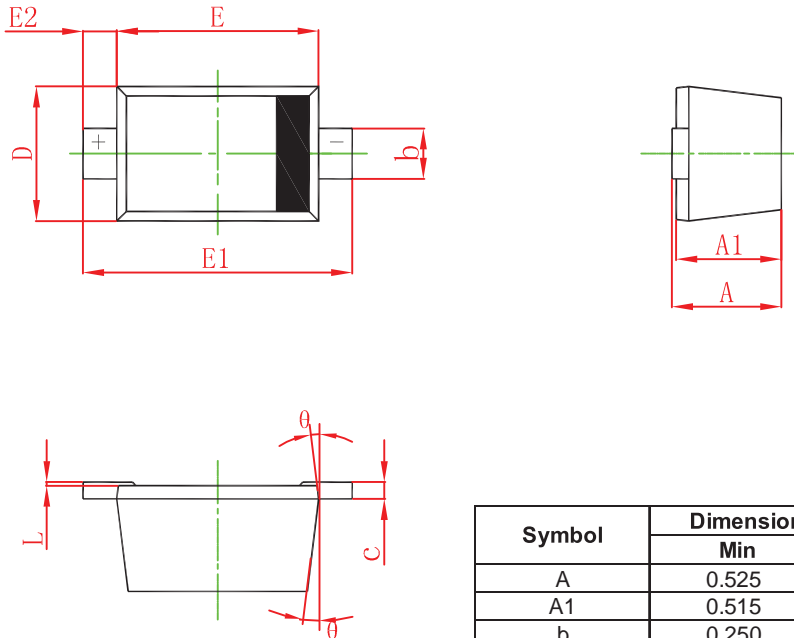

Symbol	Dimensions In Millimeters		Dimensions In Inches	
	Min	Max	Min	Max
A	0.525	0.650	0.021	0.026
A1	0.515	0.580	0.020	0.023
b	0.250	0.350	0.010	0.014
c	0.080	0.150	0.003	0.006
D	0.550	0.650	0.022	0.026
E	0.900	1.100	0.035	0.043
E1	1.300	1.500	0.051	0.059
E2	0.200 REF		0.008 REF	
L	0.010	0.070	0.001	0.003
θ	7° REF		7° REF	

SOD- 723 Suggested Pad Layout

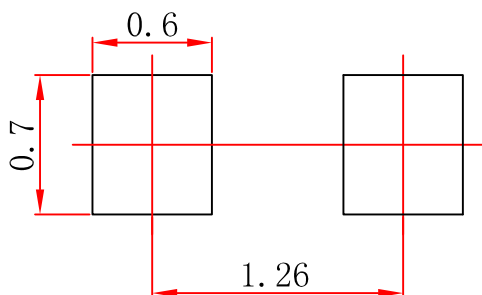

Note:

1. Controlling dimension: in millimeters.
2. General tolerance: ± 0.05 mm.
3. The pad layout is for reference purposes only.

SOD-723 Tape and Reel

SOD-723 Embossed Carrier Tape

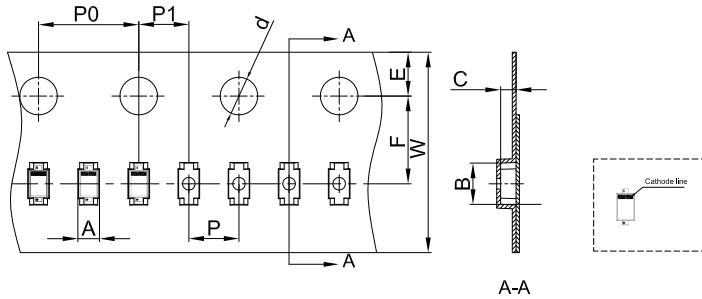

Packaging Description:

SOD-723 parts are shipped in tape. The carrier tape is made from a dissipative (carbon filled) polycarbonate resin. The cover tape is a multilayer film (Heat Activated Adhesive in nature) primarily composed of polyester film, adhesive layer, sealant, and anti-static sprayed agent. These reeled parts in standard option are shipped with 8,000 units per 7" or 17.8cm diameter reel. The reels are clear in color and is made of polystyrene plastic (anti-static coated).

Note: If it is the product of the same polarity, the cathode line should be removed.

Dimensions are in millimeter										
Pkg type	A	B	C	d	E	F	P0	P	P1	W
SOD-723	0.73	1.71	0.62	Ø1.50	1.75	3.50	4.00	2.00	2.00	8.00

SOD-723 Tape Leader and Trailer

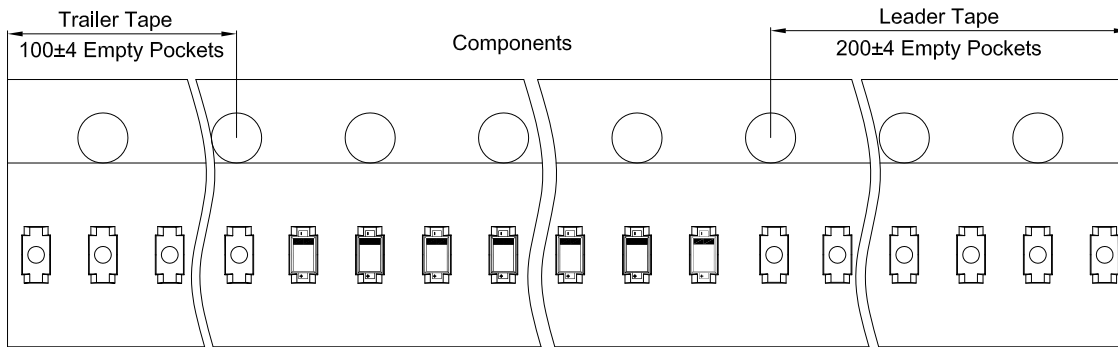

SOD-723 Reel

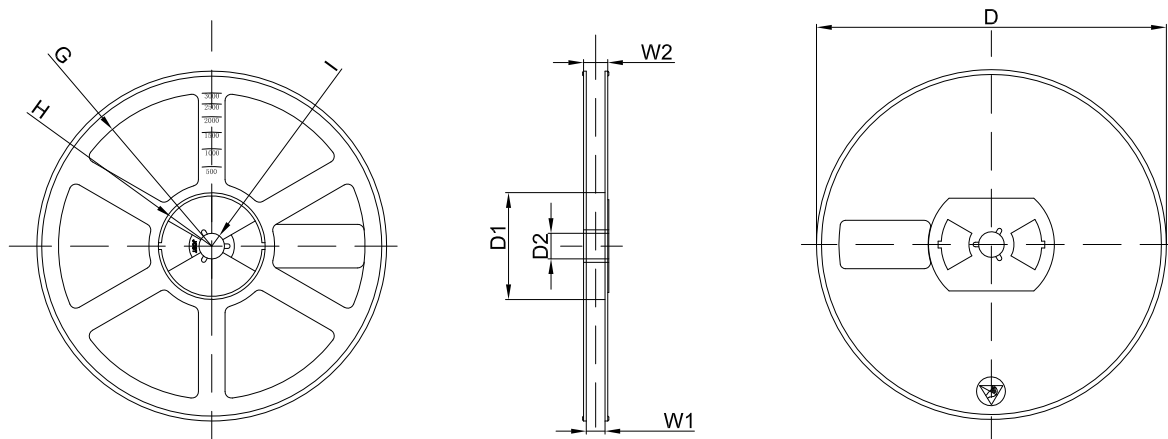

Dimensions are in millimeter								
Reel Option	D	D1	D2	G	H	I	W1	W2
7"Dia	Ø178.00	54.40	13.00	R78.00	R25.60	R6.50	9.50	12.30

REEL	Reel Size	Box	Box Size(mm)	Carton	Carton Size(mm)	G.W.(kg)
8000 pcs	7 inch	120,000 pcs	203×203×195	480,000 pcs	438×438×220	