

SURFACE MOUNT SILICON ZENER DIODES

Vz : 3.3 – 200 Volts, Pd : 3 Watts

Features

- Total power dissipation: Max. 3 W.
- Wide zener reverse voltage range 3.3V to 200V.
- Small plastic package suitable for surface mounted design.

Mechanical Data

- Case: SMB
- Terminals: Solderable per MIL-STD-750, Method 2026
- Approx. Weight: 0.095g / 0.0034oz

PINNING

PIN	DESCRIPTION
1	Cathode
2	Anode

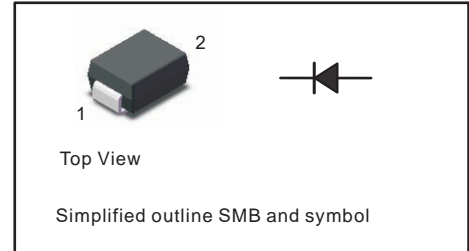

Maximum Ratings and Electrical characteristics

Ratings at 25 °C ambient temperature unless otherwise specified.

Single phase half-wave 60 Hz, resistive or inductive load, for capacitive load current derate by 20 %.

Absolute Maximum Ratings and Thermal performance(T_A = 25°C)

Parameter	Symbol	Value	Unit
DC power dissipation at TL=75°C, measure at zero lead length (Note 1) derate above 75°C	P _D	3.0	W
		40	mW/°C
Maximum Steady State Power Dissipation @ TA=25°C Derate above 25°C	P _D	550	mW
		4.4	mW/°C
Junction to ambient thermal resistance	R _{thJA}	226	°C/W
Junction to lead thermal resistance	R _{thJL}	25	°C/W
Junction Temperature Range	T _J	- 55 to + 150	°C
Storage Temperature Range	T _{STG}	- 55 to + 150	°C

Note : 1. Mounted on Cu-Pad size 5mm x 5mm on PCB.

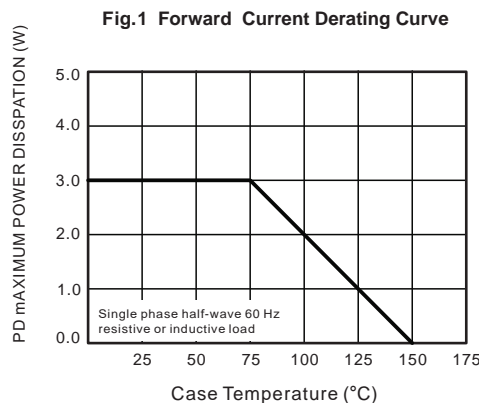

Electrical Characteristics ($T_L = 30^\circ\text{C}$ unless otherwise noted)

($V_F = 1.5\text{ V Max.}$ @ $I_F = 200\text{ mA(DC)}$ for all types)

Symbol	Parameter
V_Z	Reverse Zener Voltage @ I_{ZT}
I_{ZT}	Reverse Current
Z_{ZT}	Maximum Zener Impedance @ I_{ZT}
I_{ZK}	Reverse Current
Z_{ZK}	Maximum Zener Impedance @ I_{ZK}
I_R	Reverse Leakage Current @ V_R
V_R	Reverse Voltage
I_F	Forward Current
V_F	Forward Voltage @ I_F
I_{ZM}	Maximum DC Zener Current

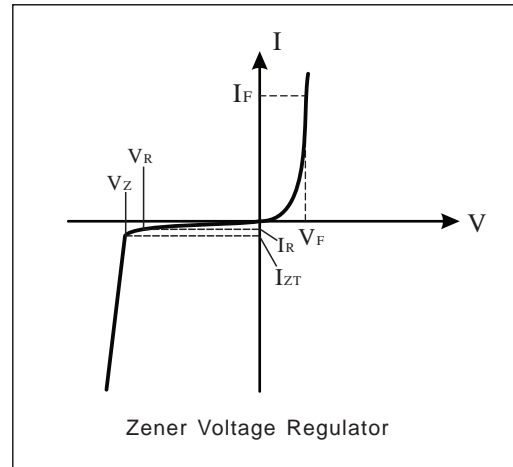

Notes On Page 3:

1. Tolerance and type number designation the type numbers listed indicate a tolerance of 5%

2. Zener voltage (V_Z) measurement

Nominal Zener voltage is measured with the device junction in thermal equilibrium with ambient temperature 25°C

3. Zener impedance (Z_Z) derivation : Z_{ZT} and Z_{ZK} are measured by dividing the AC voltage drop across the device by the AC current applied.

The specified limits are for $I_Z(\text{AC}) = 0.1 I_Z(\text{DC})$ with the AC frequency = 60 Hz



1SMB5913B ~ 1SMB5956B

Electrical Characteristics($T_A=25^\circ\text{C}$)

(TL = 30°C unless otherwise noted, VF = 1.5 V Max. @ IF = 200 mA(DC) for all types)

Type	Marking	Nominal Zener Voltage ⁽³⁾				Zener Impedance ⁽⁴⁾			Leakage Current		Maximum DC Zener Current
		V _Z			I _{ZT}	Z _{ZT} @ I _{ZT}	Z _{ZK} @ I _{ZK}		I _R @ V _R		
		Min (V)	Nom (V) ⁽²⁾	Max (V)	(mA)	(Ω)	(Ω)	(mA)	(μA)	(V)	I _{ZM} (mA)(DC)
1SMB5913B	913B	3.13	3.3	3.47	113.6	10	500	1	100	1	454
1SMB5914B	914B	3.42	3.6	3.78	104.2	9	500	1	75	1	416
1SMB5915B	915B	3.70	3.9	4.10	96.1	7.5	500	1	25	1	384
1SMB5916B	916B	4.08	4.3	4.52	87.2	6	500	1	5	1	348
1SMB5917B	917B	4.46	4.7	4.94	79.8	5	500	1	5	1.5	319
1SMB5918B	918B	4.84	5.1	5.36	73.5	4	350	1	5	2	294
1SMB5919B	919B	5.32	5.6	5.88	66.9	2	250	1	5	3	267
1SMB5920B	920B	5.89	6.2	6.51	60.5	2	200	1	5	4	241
1SMB5921B	921B	6.46	6.8	7.14	55.1	2.5	200	1	5	5.2	220
1SMB5922B	922B	7.12	7.5	7.88	50	3	400	0.5	5	6	200
1SMB5923B	923B	7.79	8.2	8.61	45.7	3.5	400	0.5	5	6.5	182
1SMB5924B	924B	8.64	9.1	9.56	41.2	4	500	0.5	5	7	164
1SMB5925B	925B	9.5	10	10.5	37.5	4.5	500	0.25	5	8	150
1SMB5926B	926B	10.45	11	11.55	34.1	5.5	550	0.25	1	8.4	136
1SMB5927B	927B	11.4	12	12.6	31.2	6.5	550	0.25	1	9.1	125
1SMB5928B	928B	12.35	13	13.65	28.8	7	550	0.25	1	9.9	115
1SMB5929B	929B	14.25	15	15.75	25	9	600	0.25	1	11.4	100
1SMB5930B	930B	15.2	16	16.8	23.4	10	600	0.25	1	12.2	93
1SMB5931B	931B	17.1	18	18.9	20.8	12	650	0.25	1	13.7	83
1SMB5932B	932B	19	20	21	18.7	14	650	0.25	1	15.2	75
1SMB5933B	933B	20.9	22	23.1	17	17.5	650	0.25	1	16.7	68
1SMB5934B	934B	22.8	24	25.2	15.6	19	700	0.25	1	18.2	62
1SMB5935B	935B	25.65	27	28.35	13.9	23	700	0.25	1	20.6	55
1SMB5936B	936B	28.5	30	31.5	12.5	28	750	0.25	1	22.8	50
1SMB5937B	937B	31.35	33	34.65	11.4	33	800	0.25	1	25.1	45
1SMB5938B	938B	34.2	36	37.8	10.4	38	850	0.25	1	27.4	41
1SMB5939B	939B	37.05	39	40.95	9.6	45	900	0.25	1	29.7	38
1SMB5940B	940B	40.85	43	45.15	8.7	53	950	0.25	1	32.7	34
1SMB5941B	941B	44.65	47	49.35	8	67	1000	0.25	1	35.8	31
1SMB5942B	942B	48.45	51	53.55	7.3	70	1100	0.25	1	38.8	29
1SMB5943B	943B	53.2	56	58.8	6.7	86	1300	0.25	1	42.6	26
1SMB5944B	944B	58.9	62	65.1	6	100	1500	0.25	1	47.1	24
1SMB5945B	945B	64.6	68	71.4	5.5	120	1700	0.25	1	51.7	22
1SMB5946B	946B	71.25	75	78.75	5	140	2000	0.25	1	56	20
1SMB5947B	947B	77.9	82	86.1	4.6	160	2500	0.25	1	62.2	18
1SMB5948B	948B	86.45	91	95.55	4.1	200	3000	0.25	1	69.2	16
1SMB5949B	949B	95	100	105	3.7	250	3100	0.25	1	76	15
1SMB5950B	950B	104.5	110	115.5	3.4	300	4000	0.25	1	83.6	13
1SMB5951B	951B	114	120	126	3.1	380	4500	0.25	1	91.2	12
1SMB5952B	952B	123.5	130	136.5	2.9	450	5000	0.25	1	98.8	11
1SMB5953B	953B	142.5	150	157.5	2.5	600	6000	0.25	1	114	10
1SMB5954B	954B	152	160	168	2.3	700	6500	0.25	1	121.6	9
1SMB5955B	955B	171	180	189	2.1	900	7000	0.25	1	136.8	8
1SMB5956B	956B	190	200	210	1.9	1200	8000	0.25	1	152	7

Package Outline

Plastic surface mounted package; 2 leads

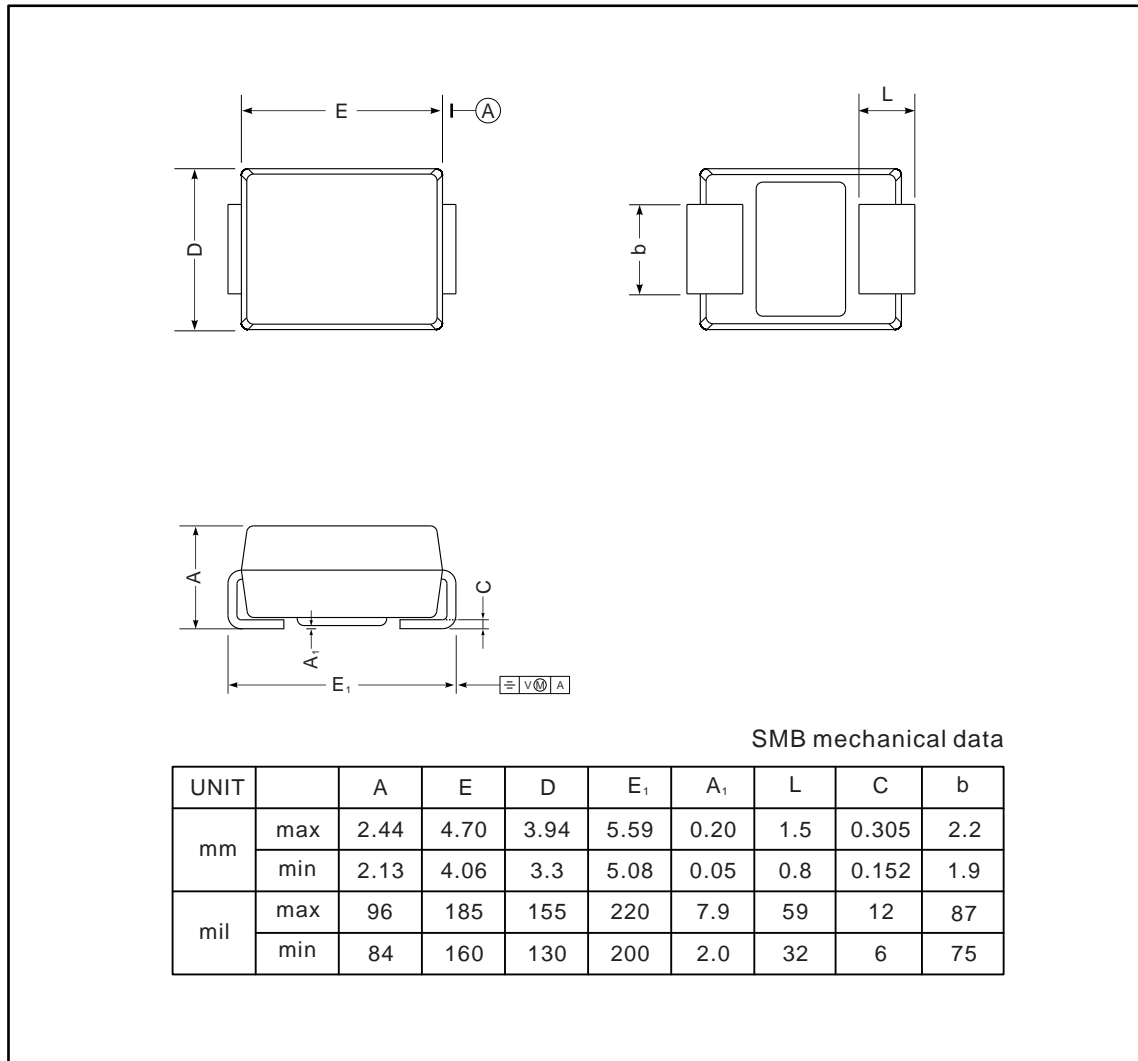

The recommended mounting pad size

