

2-Line Ultra Low Capacitance TVS Diode Array

Description

The FTV0582B is an ultra low capacitance TVS array, utilizing leading monolithic silicon technology to provide fast response time and low ESD clamping voltage, making this device an ideal solution for protecting voltage sensitive high-speed data lines.

The FTV0582B has very low capacitance with a typical value at 0.3pF, and complies with the IEC 61000-4-2 (ESD) standard with $\pm 25\text{kV}$ air and $\pm 20\text{kV}$ contact discharge. It is assembled into a 3-pin lead-free SOT-523 package. The combination of small size, low capacitance and high level of ESD protection makes it ideal for HDMI, MDDI, antenna circuits, USB 2.0, and infiniband circuits.

Features

- ◆ Ultra low capacitance: 0.3pF typical (I/O to I/O)
- ◆ Ultra low leakage: nA level
- ◆ Operating voltage: 5V
- ◆ Low clamping voltage
- ◆ Up to 2 data lines protects
- ◆ Complies with following standards:
 - IEC 61000-4-2 (ESD) immunity test
Air discharge: $\pm 25\text{kV}$
Contact discharge: $\pm 20\text{kV}$
 - IEC61000-4-5 (Lightning) 5A (8/20 μs)
- ◆ RoHS Compliant

Mechanical Characteristics

- ◆ Package: SOT-523
- ◆ Lead Finish: Matte Tin
- ◆ Case Material: "Green" Molding Compound.
- ◆ Moisture Sensitivity: Level 3 per J-STD-020
- ◆ Terminal Connections: See Diagram Below
- ◆ Marking Information: See Below

Applications

- ◆ Mobile Display Digital Interface(MDDI)
- ◆ USB 2.0
- ◆ Photodetector Protection
- ◆ HBT Power Amplifier Protection
- ◆ Infiniband Transceiver Protection
- ◆ Firewire Ports

Dimensions and Pin Configuration

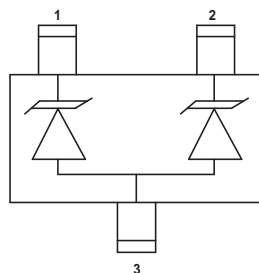
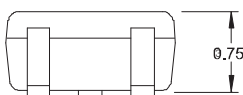
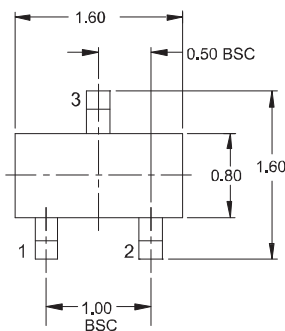

Marking Information

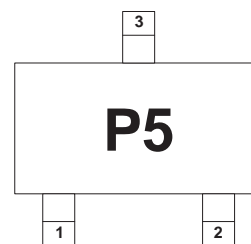

P5 = Device Marking Code

SOT- 523 outline

Circuit and Pin Schematic

Ordering Information

Part Number	Marking	Packaging	Reel Size
FTV0582B	P5	3000/Tape & Reel	7 inch



FTV0582B

2-Line Ultra Low Capacitance TVS Diode Array

Absolute Maximum Ratings ($T_A=25^{\circ}\text{C}$ unless otherwise specified)

Parameter	Symbol	Value	Unit
Peak Pulse Power (8/20 μs)	Ppk	80	W
Peak Pulse Current (8/20 μs)	I _{PP}	5	A
ESD per IEC 61000-4-2 (Air) ESD per IEC 61000-4-2 (Contact)	V _{ESD}	± 25 ± 20	kV
Operating Temperature Range	T _J	-55 to +125	$^{\circ}\text{C}$
Storage Temperature Range	T _{stg}	-55 to +150	$^{\circ}\text{C}$

Electrical Characteristics ($T_A=25^{\circ}\text{C}$ unless otherwise specified)

Parameter	Symbol	Min	Typ	Max	Unit	Test Condition
Reverse Working Voltage	V _{RWM}			5	V	Pin 1 or pin 2 to pin 3 and between pin 1 and pin 2
Breakdown Voltage	V _{BR}	6			V	I _T =1mA, pin 1 or pin 2 to pin 3
Reverse Leakage Current	I _R			0.5	μA	V _{RWM} = 5V, pin 1 or pin 2 to pin 3 and between pin1 and pin 2
Clamping Voltage	V _C			9	V	I _{PP} = 1A (8 x 20 μs pulse), pin 1 pin 2
Clamping Voltage	V _C			16	V	I _{PP} = 5A (8 x 20 μs pulse), pin 1 or pin 2 to pin 3
Junction Capacitance	C _J		0.3		pF	V _R = 0V, f = 1MHz, pin 1 to pin 2
Junction Capacitance	C _J		0.6	0.8	pF	V _R = 0V, f = 1MHz, pin 1 or pin 2 to pin 3



FTV0582B

2-Line Ultra Low Capacitance TVS Diode Array

Typical Performance Characteristics (TA=25°C unless otherwise Specified)

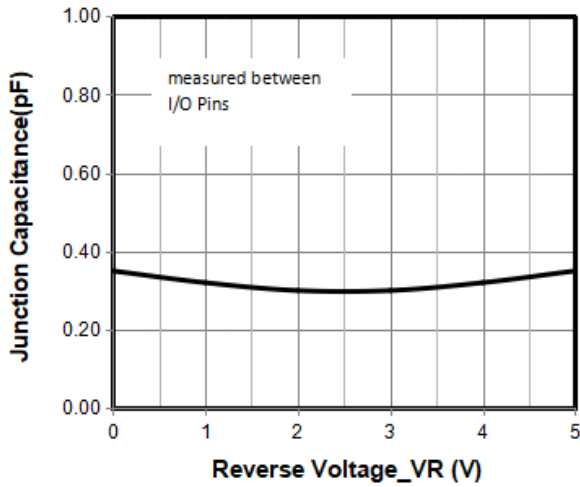

Junction Capacitance vs. Reverse Voltage

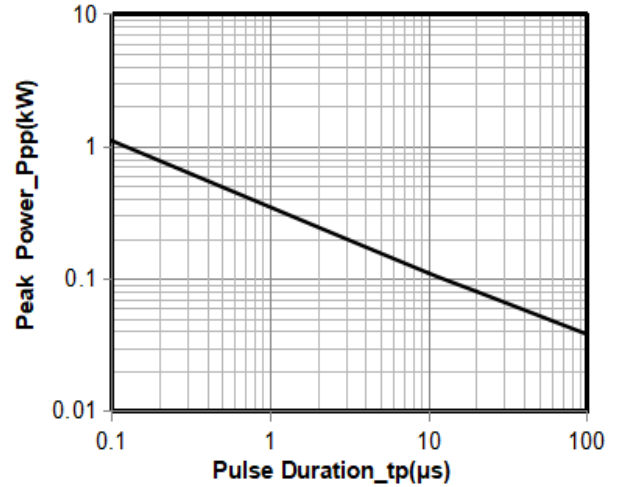

Peak Pulse Power vs. Pulse Time

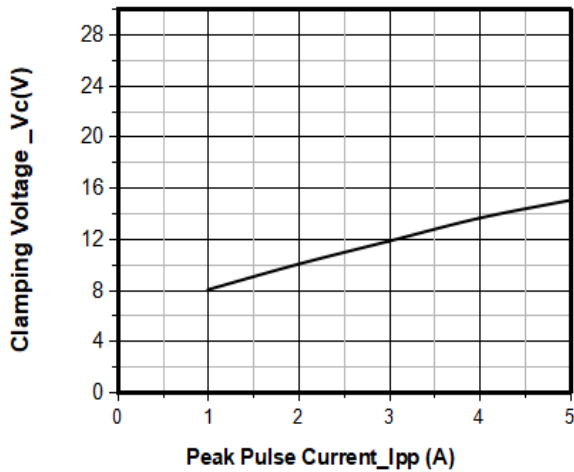

Clamping Voltage vs. Peak Pulse Current

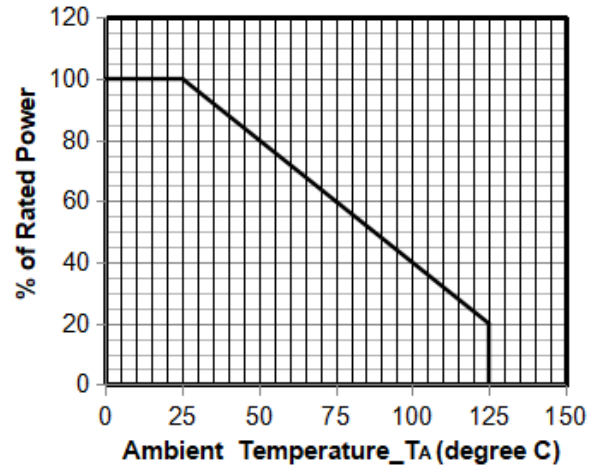

Power Derating Curve

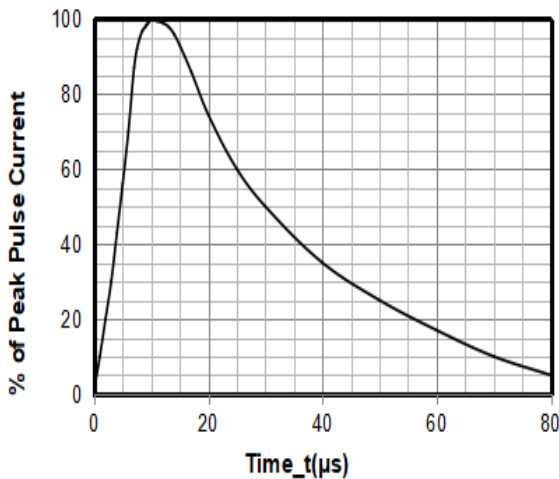

8 X 20μs Pulse Waveform

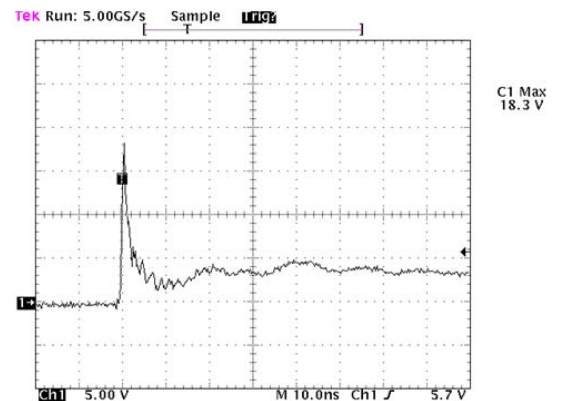

Note : Data is taken with a 10x attenuator

ESD Clamping Voltage

8 kV Contact per IEC61000-4-2



FTV0582B

2-Line Ultra Low Capacitance TVS Diode Array

FTV0582B on USB Port Application

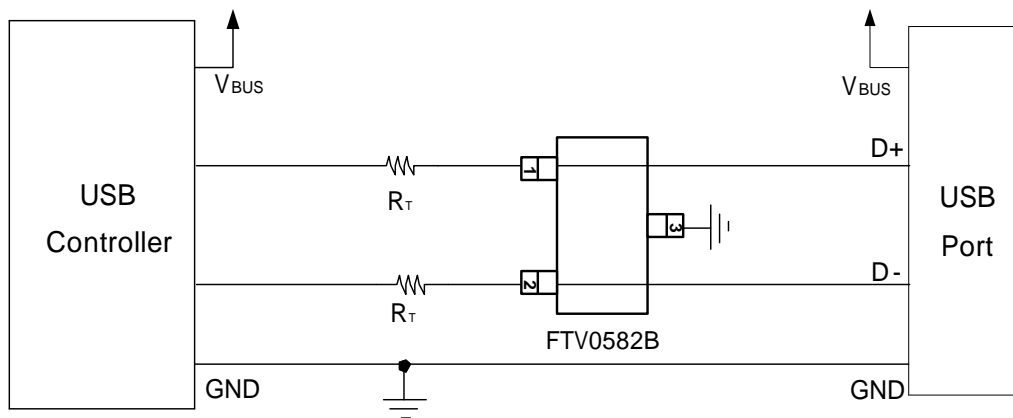



FTV0582B

2-Line Ultra Low Capacitance TVS Diode Array

SOT-523 Package Outline Drawing

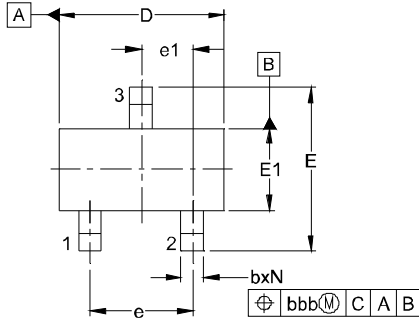

DIM	DIMENSIONS					
	INCHES			MILLIMETERS		
	MIN	NOM	MAX	MIN	NOM	MAX
A	.023	-	.035	0.60	-	0.90
A1	.000	-	.004	0.00	-	0.10
A2	.023	.030	.031	0.60	0.75	0.80
b	.005	-	.012	0.15	-	0.30
c	.003	-	.008	0.10	-	0.20
D	.059	.063	.067	1.50	1.60	1.70
E	.057	.063	.069	1.45	1.60	1.75
E1	.029	.031	.033	0.75	0.80	0.85
e	.039 BSC			1.00 BSC		
e1	.020 BSC			0.50 BSC		
L	(.009)			(0.22)		
N	3			3		
θ	0°	-	8°	0°	-	8°
aaa	.004			0.10		
bbb	.008			0.20		

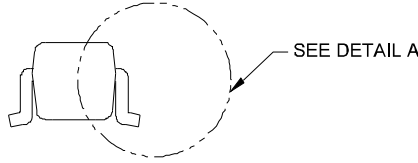
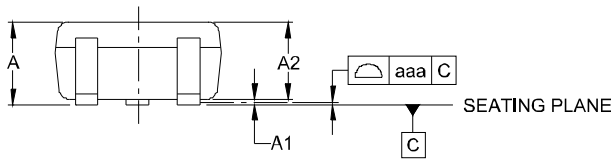

SIDE VIEW

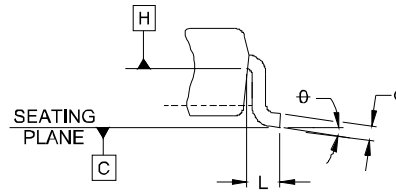

DETAIL A

Suggested Land Pattern

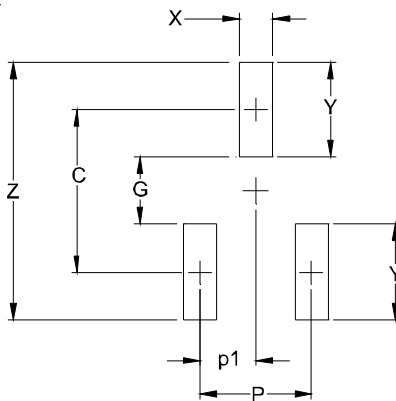

SYM	DIMENSIONS	
	INCHES	MILLIMETERS
C	(.055)	(1.40)
P	.039	1.00
P1	.020	0.50
G	.024	0.60
X	.016	0.40
Y	.031	0.80
Z	.087	2.20