

4-Line Ultra Low Capacitance TVS Diode Array

Description

The FESDUEG5V0Q4 is an ultra low capacitance TVS array, utilizing leading monolithic silicon technology to provide fast response time and low ESD clamping voltage, making this device an ideal solution for protecting voltage sensitive high-speed data lines. The FESDUEG5V0Q4 has an ultra-low capacitance with a typical value at 0.3pF, and complies with the IEC61000-4-2 (ESD) standard with $\pm 15\text{kV}$ air and $\pm 8\text{kV}$ contact discharge. It is assembled into a 6-pin lead-free SOT-363 package. The combination of small size, ultra low capacitance, and high ESD surge capability make it ideal for use in applications such as USB 3.0, multimedia, and other high speed ports.

Mechanical Characteristics

- ◆ Package: SOT-363
- ◆ Lead Finish: Matte Tin
- ◆ Case Material: "Green" Molding Compound
- ◆ Moisture Sensitivity: Level 3 per J-STD-020
- ◆ Terminal Connections: See Diagram Below
- ◆ Marking Information: See Below

Features

- ◆ Ultra low capacitance: 0.3pF typical (I/O to I/O)
- ◆ Ultra low leakage: nA level
- ◆ Low clamping voltage
- ◆ Operating voltage: 5V
- ◆ Up to 4 data lines and one power line protects
- ◆ Complies with following standards:
 - IEC 61000-4-2 (ESD) immunity test
 - Air discharge: $\pm 15\text{kV}$
 - Contact discharge: $\pm 8\text{kV}$
 - IEC61000-4-5 (Lightning) 5A (8/20 μs)
- ◆ ROHS Compliant

Applications

- ◆ USB 2.0 and USB 3.0 Ports
- ◆ USB OTG
- ◆ Digital Visual Interface(DVI)
- ◆ Monitor and Flat Panel Displays
- ◆ PCI Express and Serial SATA Ports
- ◆ Gigabit Ethernet
- ◆ IEEE 1394 Firewire Ports
- ◆ Consumer products(STB, DVD ,DSC, DVC...)

Dimensions and Pin Configuration

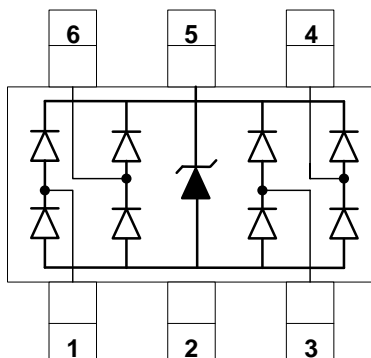

Circuit and Pin Schematic

Marking Information

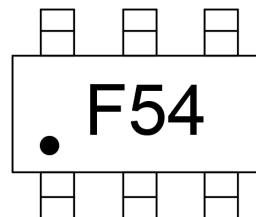

F54 = Device Marking Code
Dot denotes Pin1

Ordering Information

Part Number	Marking	Packaging	Reel Size
FESDUEG5V0Q4	F54	3000/Tape & Reel	7 inch



4-Line Ultra Low Capacitance TVS Diode Array

Absolute Maximum Ratings ($T_A=25^{\circ}\text{C}$ unless otherwise specified)

Parameter	Symbol	Value	Unit
Peak Pulse Power (8/20 μs)	Ppk	75	W
Peak Pulse Current (8/20 μs)	I _{PP}	5	A
ESD per IEC 61000-4-2 (Air) ESD per IEC 61000-4-2 (Contact)	V _{ESD}	± 15 ± 8	kV
Operating Temperature Range	T _J	-55 to +125	$^{\circ}\text{C}$
Storage Temperature Range	T _{stg}	-55 to +150	$^{\circ}\text{C}$

Electrical Characteristics ($T_A=25^{\circ}\text{C}$ unless otherwise specified)

Parameter	Symbol	Min	Typ	Max	Unit	Test Condition
Reverse Working Voltage	V _{RWM}			5	V	Any I/O pin to ground
Breakdown Voltage	V _{BR}	6			V	I _T = 1mA, any I/O pin to ground
Reverse Leakage Current	I _R			0.5	μA	V _{RWM} = 5V, any I/O pin to ground
Clamping Voltage	V _C			10	V	I _{PP} = 1A (8 x 20 μs pulse), any I/O pin to ground
Clamping Voltage	V _C			15	V	I _{PP} = 5A (8 x 20 μs pulse), any I/O pin to ground
Junction Capacitance	C _J		0.3	0.4	pF	V _R = 0V, f = 1MHz, between I/O pins
Junction Capacitance	C _J			0.8	pF	V _R = 0V, f = 1MHz, any I/O pin to ground

Note 1: I/O pins are Pin 1, 3, 4 and 6



4-Line Ultra Low Capacitance TVS Diode Array

Typical Performance Characteristics (TA=25°C unless otherwise Specified)

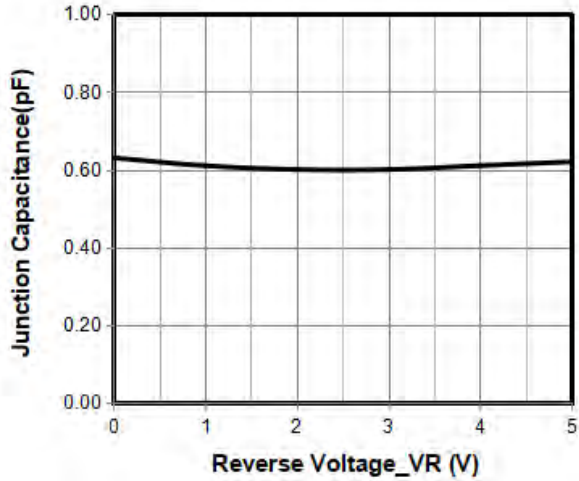

Junction Capacitance vs. Reverse Voltage

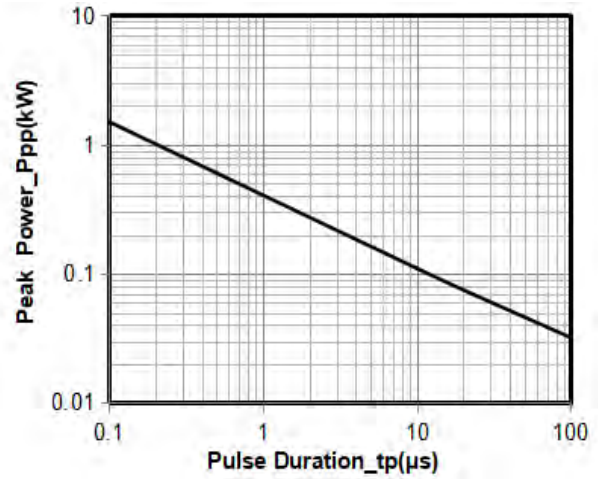

Peak Pulse Power vs. Pulse Time

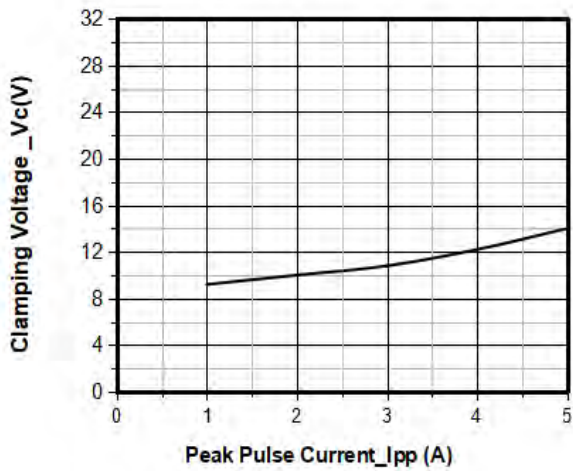

Clamping Voltage vs. Peak Pulse Current

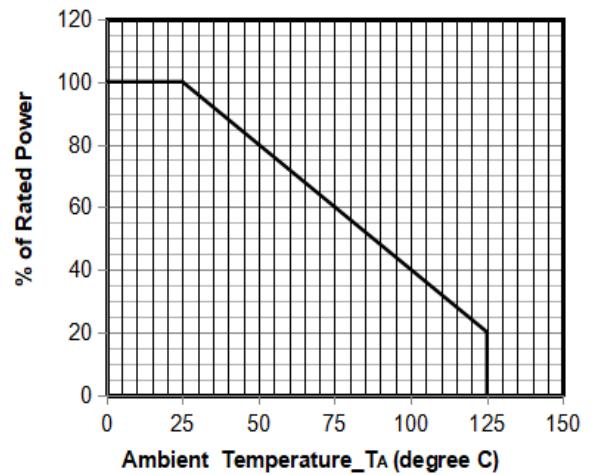

Power Derating Curve

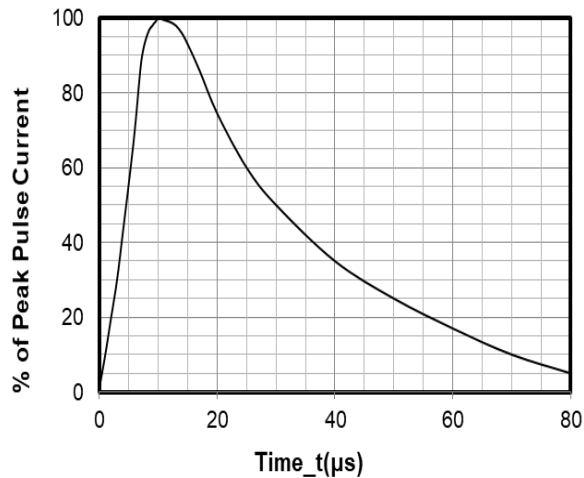

8 X 20μs Pulse Waveform

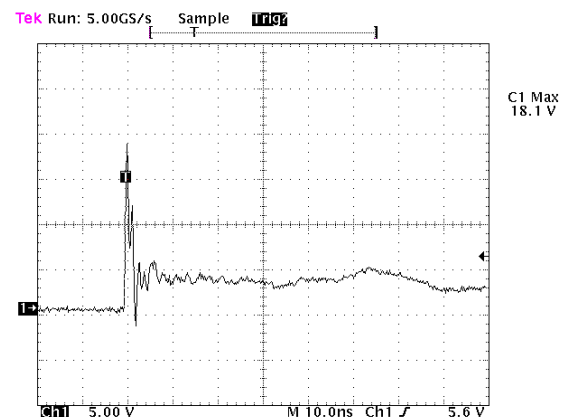

Note : Data is taken with a 10x attenuator

ESD Clamping Voltage

8 kV Contact per IEC61000-4-2

4-Line Ultra Low Capacitance TVS Diode Array

SOT-363 Package Outline Drawing

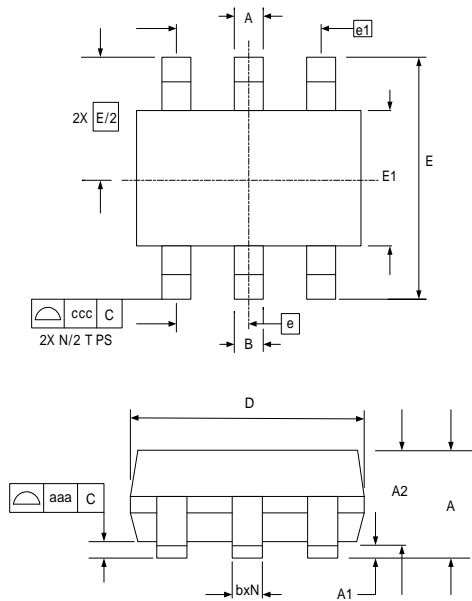

SYM	DIMENSIONS					
	MILLIMETERS			INCHES		
	MIN	NOM	MAX	MIN	NOM	MAX
A			1.10			0.043
A1	0.00		0.10	0.000		0.004
A2	0.70	0.90	1.00	0.028	0.035	0.039
b	0.15		0.30	0.006		0.012
c	0.08		0.22	0.003		0.009
D	1.80	2.00	2.20	0.071	0.079	0.087
E1	1.15	1.25	1.35	0.045	0.049	0.053
E	2.10 BSC			0.083 BSC		
e	0.65 BSC			0.026 BSC		
e1	1.30 BSC			0.051 BSC		
N	6			6		
aaa	0.10			0.004		
ccc	0.30			0.012		

Suggested Land Pattern

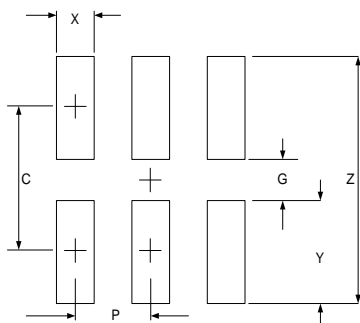

SYM	DIMENSIONS	
	MILLIMETERS	INCHES
C	1.85	0.073
G	1.00	0.039
P	0.65	0.026
X	0.40	0.016
Y	0.85	0.033
Z	2.70	0.106